

RSO872

RS485 开环步进驱动器使用手册

RS485 OPEN LOOP STEP MOTOR DRIVE User's Manual



摩川技术(深圳) 有限公司

Moschon Technology (Shenzhen) Co. , Ltd.

该产品由深圳市泰奇科智能技术有限公司独家发行，版权所有！

目录

前言/Foreword	3
1 概述/Overview	4
1.1 产品介绍/Product Introduction.....	4
1.2 特性/Characteristics.....	4
1.3 应用领域/Application areas.....	5
2 性能指标/Performance Index	5
2.1 电气特性/Electrical characteristics.....	5
2.2 使用环境/Use environment.....	6
3 安装/Installation	6
3.1 安装尺寸/Mounting dimensions.....	6
3.2 安装方法/Installation method.....	7
4 驱动器端口与接线/Driver ports and wiring	7
4.1 接线示意图/Schematic diagram of wiring.....	7
4.2 端口定义/Port Definition.....	8
5 拨码开关的设置说明/Instructions for setting the dial switch	12
6 通讯和通讯协议说明	13
6.1 网络布局.....	14
6.2 通讯协议.....	14
6.3 回零功能.....	16
6.4 MODBUS 常用功能码.....	17
6.5 CRC 校验例程.....	18
7 保修及售后服务 /Warranty and after-sales service	19

前言/Foreword

感谢您使用本公司开环步进驱动器。

Thank you for using our open step drive.

在使用本产品前，请务必仔细阅读本手册，了解必要的安全信息、注意事项以及操作方法等。错误的操作可能引发极其严重的后果。

Before using this product, please read this manual carefully to understand the necessary safety information, precautions, and operation methods. Incorrect operation can have extremely serious consequences.

本产品的设计和制造不具备保护人身安全免受机械系统威胁的能力，请用户在机械系统设计和制造过程中考虑安全防护措施，防止因不当的操作或产品异常造成事故。

This product is designed and manufactured without the ability to protect personal safety from mechanical system threats. Users are advised to consider safety precautions during mechanical system design and manufacturing to prevent accidents caused by improper operation or product abnormalities.

由于产品的改进，手册内容可能变更，恕不另行通知。用户对产品的任何改装我公司将不承担任何责任。阅读时，请注意手册中的以下标示：

Due to product improvements, the contents of this manual are subject to change without notice. Our company will not be responsible for any modification of the product by the user.

When reading, please pay attention to the following signs in the manual:



注意：提醒您注意文字中的要点。



小心：表示错误的操作可能导致人身伤害和设备损坏。

本产品经过国家强制 3C 认证，CE 认证，ROHS 认证

This product has passed the national mandatory 3C certification, CE certification, ROHS certification



1 概述/Overview

1.1 产品介绍/Product Introduction

RS0872 是我公司推出的 Modle Bus 标准 RS485 总线型驱动器，采用最新 32 位 DSP 数字处理技术，驱动器控制算法采用先进的变电流技术和先进的变频技术，驱动器发热小，电机振动小，运行平稳。用户可以设置 1-255 内的任意 ID 地址以及额定电流内的任意电流值，能够满足大多数场合的应用需要。该总线型驱动器可以驱动两相开环步进电机，三相开环步进电机，混合伺服电机，直流无刷伺服电机等。由于采用内置微细分技术，即使在低细分的条件下，也能够达到高细分的效果，低中高速运行都很平稳，噪音超小。驱动器内部集成了参数上电自动整定功能，能够针对不同电机自动生成最优运行参数，最大限度发挥电机的性能。

RS0872 is the RS485 Bus driver of Modle Bus Standard introduced by our company. It adopts the latest 32-bit DSP digital processing technology. The driver control algorithm adopts advanced variable current technology and advanced frequency conversion technology. The driver generates less heat and the motor vibrates less, smooth operation. The user can set any ID address within 1-255 and any current value within the rated current, which can meet the needs of most applications. The bus driver can drive two-phase open-loop stepper motor, three-phase open-loop stepper motor, hybrid servo motor, brushless DC servo motor, etc. . Due to the use of built-in micro-subdivision technology, even in the conditions of low subdivision, but also can achieve high subdivision effect, low, medium and high-speed operation is very smooth, ultra-low noise. The auto-tuning function is integrated in the driver, which can automatically generate the optimal operating parameters for different motors and maximize the performance of the motors.

1.2 特性/Characteristics

- 全新 32 位 DSP 技术

New 32-bit DSP technology

- 1 路 0-10V 模拟量输入

1 way 0-5V analog input

- 2 路光耦隔离 OC 输出

Four-way optocoupler isolated OC output

- 参数上电自动匹配电机功能

Automatic parameter power-on setting function

- 变电流控制使电机发热大为降低

Variable current control greatly reduces the heat generation of the motor.

- 静止时电流自动减半

The current is automatically halved at rest

- 可驱动多种步进电机

Can drive a variety of loop stepper motor

- 5 路光电隔离信号输入，其中 2 路为高速光耦隔离

5 photoelectricity isolation signal inputs, 2 of which are high-speed optocoupler isolation

- 通讯频率最高可达 1MHz (出厂默认 9600Hz)

COMMUNICATION FREQUENCY UP TO 1MHZ (factory Default 9600HZ)

- 电流设定方便，可在 0.1-7.2A 之间任意选择 Easy to set the current, can be in between 0.1-8.0 a arbitrary choice

●具有过压、欠压、过流等保护功能

With over-voltage, under-voltage, over-current and other protection functions

1.3 应用领域/Application areas

适合各种中小型自动化设备和仪器，例如：AGV，速通门，雕刻机、打标机、切割机、激光照排、绘图仪、数控机床、自动装配设备等。在用户期望小噪声、高速度的设备中应用效果特佳。

Suitable for all kinds of small and medium-sized automatic equipment and instruments, such as AGV, speed door, engraving machine, marking machine, cutting machine, laser phototypesetting, plotter, CNC machine tools, automatic assembly equipment, etc. . It works especially well on devices that users expect to have low noise and high speed.

2 性能指标/Performance Index

2.1 电气特性/Electrical characteristics

说明 Account for	RS0872			
	最小值 Minimum value	典型值 Typical value	最大值 Maximum value	单位 Unit
输出电流(峰值) Output Current (peak)	0.1	-	7.2	A
输入电源电压(直流) Input Power Supply Voltage (DC)	24	24/36/48	75	VDC
控制信号输入电流 Control signal input current	6	10	16	mA
控制信号接口电平 Control signal interface level	5	5	24	Vdc
OC 输出上拉电压 OC output pull-up voltage	5	-	24	Vdc
RS485 通讯频率 RS485 frequency	1		1000	KHz
模拟电压输入 Analog voltage input	0		5	Vdc
绝缘电阻 Insulation Resistance	100			MΩ

2.2 使用环境/Use environment

冷却方式 Cooling Mode		自然冷却或强制风冷 Natural Cooling or forced air cooling
使用环境 Service Environment	场合 Occasion	不能放在其它发热的设备旁，要避免粉尘、油雾、腐蚀性气体，湿度太大及强振动场所，禁止有可燃气体和导电灰尘。 Can not be placed next to other heating equipment, to avoid dust, oil mist, corrosive gases, humidity is too large and strong vibration sites, prohibited combustible gases and conductive dust.
	温度 Temperature	-10℃ ~ +50℃
	湿度 Humidity	40 ~ 90%RH
	振动 Vibration	5.9m/s ² MAX
保存温度 Storage temperature		-20℃~60℃
使用海拔 Use Elevation		1000 米以下 Below 1000 meters
重量 Weight		0.2KG

3 安装/Installation

3.1 安装尺寸/Mounting dimensions

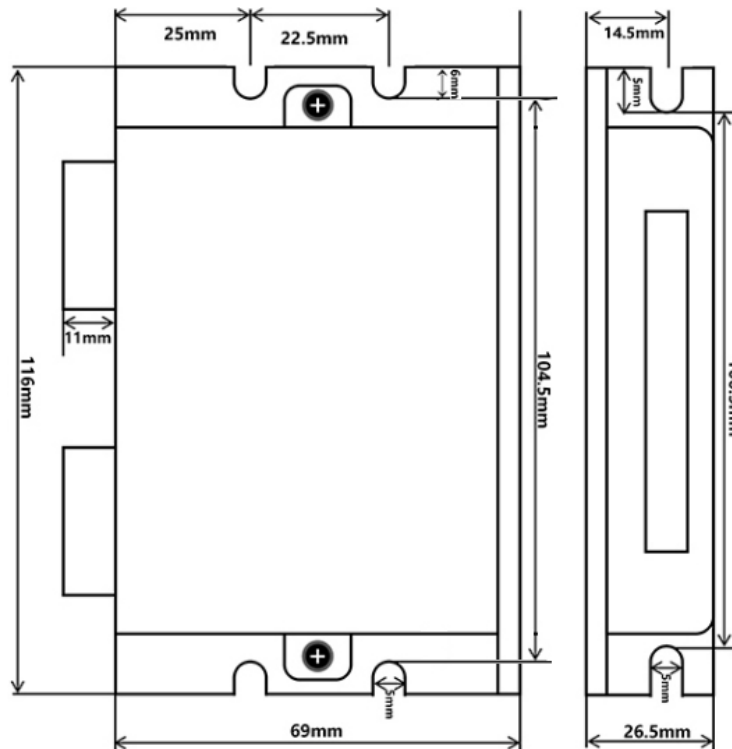

3.2 安装方法/Installation method

驱动器的可靠工作温度通常在 60℃ 以内，电机工作温度为 80℃ 以内。

The reliable operating temperature of the driver is usually within 60℃, and the motor operating temperature is within 80℃.

建议使用时选择自动半流方式，马达停止时电流自动减一半，以减少电机和驱动器的发热。

It is recommended to use the automatic semi-flow mode when using the motor. When the motor stops, the current is automatically reduced by half to reduce the heat of the motor and the drive.

安装驱动器时请采用竖着侧面安装，使散热齿形成较强的空气对流。

Install the drive with vertical side mounting so that the heat dissipating teeth form a strong air convection.

必要时机内靠近驱动器处安装风扇，强制散热，保证驱动器在可靠工作温度范围内工作。

Install a fan near the drive when necessary to force heat dissipation to ensure that the drive works within a reliable operating temperature range.

4 驱动器端口与接线/Driver ports and wiring

4.1 接线示意图/Schematic diagram of wiring

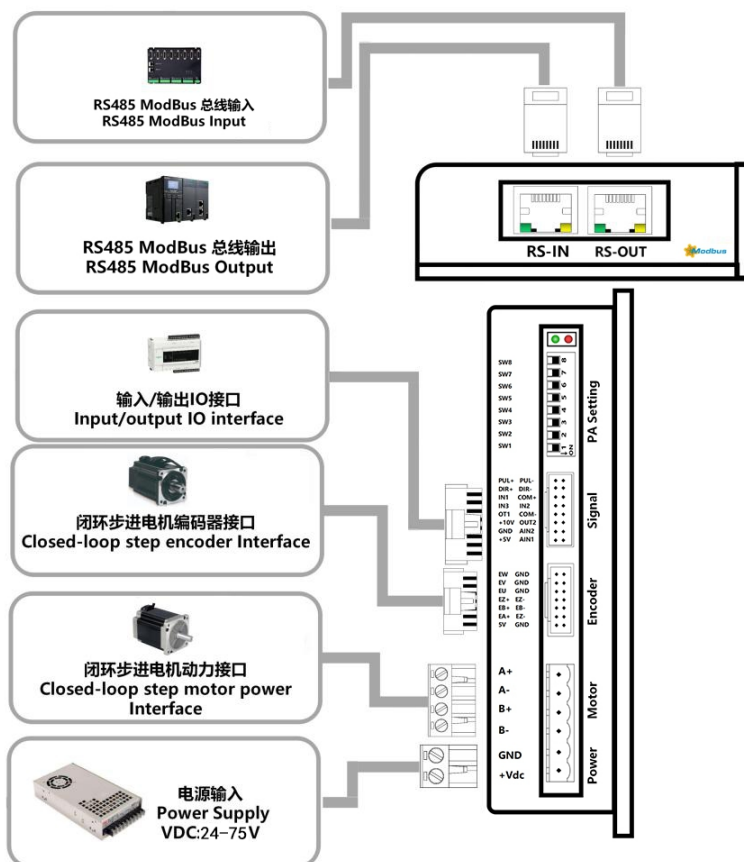



4.2 端口定义/Port Definition

4.2.1 LED 灯状态指示/Lamp status indication

左边蓝色 LED 为电源指示灯，当驱动器接通电源时，该 LED 常亮；当驱动器切断电源时，该 LED 熄灭。蓝色 LED 为故障指示灯，当出现故障时，该指示灯以 3 秒钟为周期循环闪烁；当故障被用户清除时，蓝色 LED 常灭。红色 LED 在 3 秒钟内闪烁次数代表不同的故障信息，具体关系如下表所示：

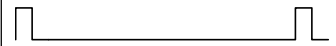
The blue LED on the left is the power indicator, which is always on when the driver is powered on, and goes out when the driver cuts off the power. The blue LED is the fault indicator, when there is a fault, the indicator lamp for 3 seconds cycle flashing; when the fault is cleared by the user, the blue LED often out. Red Led flashes in 3 seconds represent different failure information, as shown in the table below:

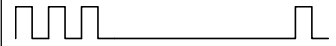
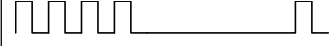
序号 No.	闪烁次数 The number of flashes	红色 LED 闪烁波形 Red LED flashes waveform	故障说明 Description of the problem
1	1		过流或相间短路故障 Overcurrent or interphase short circuit fault
2	2		过压故障 Overvoltage fault
3	3		欠压故障 Under voltage fault
4	7		超差报警 Over-tolerance alarm

4.2.2 控制信号输入端口/Control Signal Input Port

控制信号接口

Control Signal interface

名称 Name	功能 Function
PL+	高速信号：脉冲上升沿有效；p1 高电平时 5~24Vdc，低电平时 0~0.5V。为了可靠响应脉冲信号，脉冲宽度应大于 1.5 μs。
PL-	HIGH-SPEED SIGNAL: Pulse rising edge is effective, PL high level 5 ~ 24 VDC, Low Level 0 ~ 0.5 v. In order to respond reliably to the pulse signal, the pulse width should be greater than 1.5 s.
DR+	高速信号：脉冲上升沿有效；p1 高电平时 5~24Vdc，低电平时 0~0.5V。为了可靠响应脉冲信号，脉冲宽度应大于 1.5 μs。
DR-	HIGH-SPEED SIGNAL: Pulse rising edge is effective, PL high level 5 ~ 24 VDC, Low Level 0 ~ 0.5 v. In order to respond reliably to the pulse signal, the pulse width should be greater than 1.5 s.
IN+	低速信号：in1, in2, in3 的共阳极输入，电平 5-24V 兼容 Low speed signal: IN1, IN2, IN3 common anode input, level 5-24V compatible
IN1	低速信号 in1 的负极输入，负限位 Negative input of low speed signal IN1
IN2	低速信号 in2 的负极输入，正限位 Negative input of low speed signal IN2
IN3	低速信号 in3 的负极输入，预留 Negative input of low speed signal IN3
OT-	共阴极 OC 射极输出，ot1, ot2 射极 OC 输出公共端 Common Cathode OC emitter output, OT1, OT2 emitter OC output common terminal
OT1	ot1 射极输出，最大上拉电压 24Vdc，上拉电阻 2K Ω，最大输出电流 100mA，故障输出 OT1 emitter output, maximum pull-up voltage 24VDC, pull-up resistance 2K, maximum output current 100mA
OT2	ot2 射极输出，最大上拉电压 24Vdc，上拉电阻 2K Ω，最大输出电流 100mA，到位输出 OT2 emitter output, maximum pull-up voltage 24VDC, pull-up resistance 2K, maximum output current 100mA
10V	预留 Reserve
AIN2	预留 Reserve
GND	预留 Reserve
AIN	预留 Reserve
5V	预留 Reserve

4.2.3 编码器信号和霍尔信号接口/Encoder signal and Houle signal interface

名称 Name	功能 Function
EA+	闭环步进编码器预留 Closed-loop step-by-step encoder reservation
EA-	
EB+	闭环步进编码器预留 Closed-loop step-by-step encoder reservation
EB-	
EZ+	闭环步进编码器预留 Closed-loop step-by-step encoder reservation
EZ-	
EU+	无刷预留 Brushless reserve
EU-	
EV+	无刷预留 Brushless reserve
EV-	
EW+	无刷预留 Brushless reserve
EW-	
5V	给电机的编码器和霍尔元件提供直流电压 5V，电流 100mA。 It supplies the motor's encoder and Houle element with a DC voltage of 5V and a current of 100mA.
GND	5V 参考端负极 5V Reference Terminal Negative

4.2.4 电源及电机输出端口/Output ports of power supply and motor
供电与电机动力接口
Power supply and motor power interfac

名称 Name	功能 Function
GND	直流电源地 DC power source
+VDC	直流电源正极，供电电压范围：直流 24~75Vdc，推荐 24Vdc 或 36Vdc 工作。 DC Power Supply Positive Pole, supply voltage range: DC 24 ~ 75VDC, recommended 24VDC or 36VDC work.
A+	步进电机 A+相绕组接口，开环步进和闭环步进用到，直流伺服该接口不用 A phase winding interface for stepper motor, Open-loop stepping and closed-loop stepping are used, DC servo is not used for this interface
A-	步进电机 A-相绕组接口 A-phase winding interface of stepper motor
B+	步进电机 B+相绕组接口 B phase winding interface for stepper motor
B-	步进电机 B-相绕组接口 B-phase winding interface of stepper motor

电源电压在规定范围之内都可以正常工作，驱动器最好采用非稳压型直流电源供电，也可以采用变压器降压+桥式整流+电容滤波。但注意应使整流后电压纹波峰值不超过其规定的最大电压。建议用户使用低于最大电压的直流电压供电，避免电网波动超过驱动器电压工作范围。

The power supply voltage can work normally between the specified ranges. The driver is preferably powered by an unregulated DC power supply, or a transformer buck + bridge rectifier + capacitor filter. Note, however, that the peak voltage ripple after rectification should not exceed its specified maximum voltage. It is recommended that the user supply power with a DC voltage lower than the maximum voltage to prevent the grid from fluctuating beyond the operating range of the driver voltage.

如果使用稳压型开关电源供电，应注意开关电源的输出电流范围需设成最大。

If using a regulated switching power supply, be aware that the output current range of the switching power supply must be set to maximum.

请注意：

Please note:

接线时要注意电源正负极切勿反接；

When wiring, pay attention to the positive and negative poles of the power supply, do not reverse connection;

最好用非稳压型电源；

It is better to use an unstable power supply;

采用非稳压电源时，电源电流输出能力应大于驱动器设定电流的 60%即可；

The output capacity of the power supply current should be greater than 60% of the set current of the driver when an unstable power supply is used;

采用稳压开关电源时，电源的输出电流应大于或等于驱动器的工作电流；

When a regulated switching power supply is adopted, the output current of the power supply shall be greater than or equal to the working current of the driver;

为降低成本，两三个驱动器可共用一个电源，但应保证电源功率足够大。

To reduce costs, two or three drives can share a power supply, but the power supply should be large enough.

4.2.5 RS485 总线通讯接口/RS485 bus communication interface

RS485 端口为双联体带屏蔽 RJ45 端子（靠近驱动器端子侧为 16 脚）

The RS485 port is a duplex with shielded RJ45 terminals (16 pins near the driver terminal side)

引脚号 Pin Number	信号 Signal	功能说明 Function description
1	RS485-	RS485-信号，或 B RS485-SIGNAL, or B
2	RS485+	RS485+信号，或 A RS485 signal, or A
3	NC	不接，预留 No, hold
4	EGNG	信号地 Signal ground

5	EGNG	信号地 Signal ground
6	NC	不接, 预留 No, hold
7	EGNG	信号热接地屏蔽技术, 强干扰时用到 Signal hot ground shielding technology, used in strong interference
8	EGNG	信号地 Signal ground
9	RS485-	RS485-信号, 或 B RS485-SIGNAL, or B
10	RS485+	RS485+信号, 或 A RS485 signal, or A
11	RS232-RXD	RS232 串口, TTL -3.3V 电平, 串口调试设置用 RS232 serial port, TTL-3.3 V level, serial debugging settings
12	EGNG	信号地 Signal ground
13	EGNG	信号地 Signal ground
14	RS232-TX	RS232 串口, TTL -3.3V 电平, 串口调试设置用 RS232 serial port, TTL-3.3 V level, serial debugging settings
15	EGNG	信号热接地屏蔽技术, 强干扰时用到 Signal hot ground shielding technology, used in strong interference
16	NC	不接, 预留 No, hold

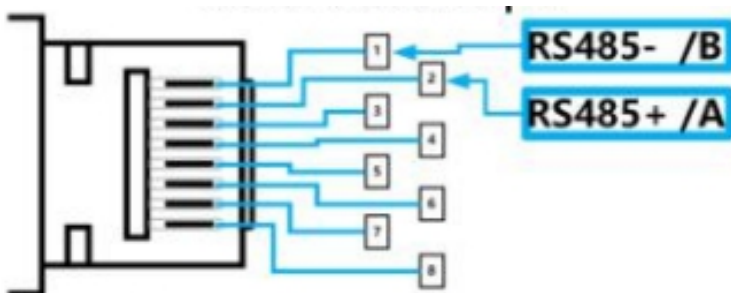

注: 上图为网口通讯信号针定义图, 输入/输出一样

5 拨码开关的设置说明/Instructions for setting the dial switch

RS0872 总线型驱动电机采用 8 位拨码开关设定 RS485 地址、波特率和终端匹配电阻选择功能, 具体设置如下:

RS0872 bus-type drive motor adopts 8-bit dial switch to set RS485 address, Baud rate and terminal matching resistance selection function, as follows:

注：低 5 位 RS485 地址由拨码设定，高 2 位 RS485 地址通过上位机设置。

Note: Low 5-bit RS485 address is set by dialing, high 2-bit RS485 address is set by host computer.

RS485 ID Table

ID	S1	S2	S3	S4	S5
Reserved(出厂默认)	0n	0n	0n	0n	0n
1	Off	0n	0n	0n	0n
2	0n	Off	0n	0n	0n
3	Off	Off	0n	0n	0n
4	0n	0n	Off	0n	0n
5	Off	0n	Off	0n	0n
.....
30	0n	Off	Off	Off	Off
31	Off	Off	Off	Off	Off

注：RS485 的 ID 表格计算值计算公式为： $ID=1*S1+2*S2+4*S3+8*S4+16*S5$ ，默认 ID 值为 0，0 表示广播地址，可以通过上位机设置其它更高的地址。

Note: The formula for calculating the value of the RS485 ID table is: $ID = 1 * S 1 + 2 * s 2 + 4 * s 3 + 8 * s 4 + 16 * S 5$. The Default ID value is 0, 0 is the broadcast address, and other higher addresses can be set through the host computer.

RS485 Baud Rate Table

Baud Rate	SW6	SW7
Default (9600Hz, 可使用上位机设定) Default (9600HZ, set by PC)	0n	0n
19200Hz	Off	0n
38400Hz	0n	Off
57600 Hz	Off	Off

RS485 终端电阻选择/Can Terminal Resistance Selection

SW8: off=RS485 R off, 默认为(Default to)off; on= RS485 R on

注：在网络最末端的驱动器要求将 SW8=on。

Note: The drive at the end of the network requires SW8 = on.

6 通讯和通讯协议说明

6.1 网络布局

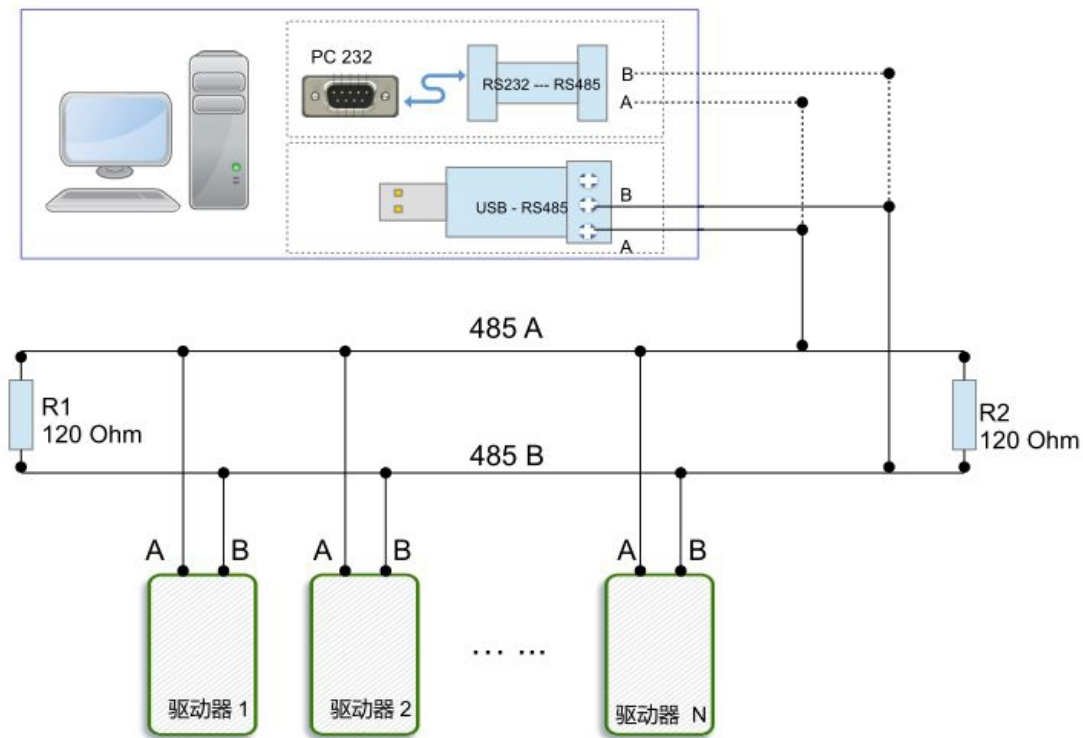

内置梯形加减速曲线生成器，可以梯形加减速，通过通讯命令实现定长运行，连续运行，减速停止，立即停止。内部运行支持绝对位置模式和相对位置模式控制，内置常用回零功能，简化开发。内部脉冲发生器采用 32 位速度、加速度、行程，可以实现宽范围的轨迹发生。

6.2 通讯协议

通讯采用标准 MODBUS 协议，支持 0x03(读寄存器)，0x06(写单个寄存器)，0x10(16)(写多个寄存器)。串口通讯格式：波特率 9600~115200，8 个数据位，无奇偶校验，1 个停止位。

6.2.1 MODBUS 寄存器地址定义

地址	参数名称	属性	默认值	值的范围	寄存器说明
0	峰值电流	R/W/S	5000	1~6000	单位:Ma
1	细分数	R/W/S	6000	200~51200	电机运行一圈所需要的脉冲个数。
2	待机时间	R/W/S	300	100~10000	驱动器进入待机的时间，单位:ms
3	待机电流百分比	R/W/S	50	0~100	单位:%
4	拨码状态	R			
10	滤波时间	R/W/S	4000	50~25600	设定滤波器的滤波时间:us
15	电流环 Kp	R/W/S	1000	10~32767	在自整定为使能时，该项只读；不使能时用户可改

					写。
16	电流环 Ki	R/W/S	200	0~32767	在自整定为使能时，该项只读；不使能时用户可改写。
18	波特率选择	R/W/S	96	96~1152	96 表示 9600
22	电流有效值	R/W/S	3500	1~4200	单位:Ma
31	设备 ID 号	R			
39	脉冲总数 L	R			接收的外部脉冲个数低 16bit
40	脉冲总数 H	R/W			接收的外部脉冲个数高 16bit 写：写入 1 清除计数器
48	母线电压	R			返回母线电压 单位 0.1V
51	电机运行方向	R/W/S	1	0/1	0：电机运行方向不变 1：电机运行方向取反
60	回零速度	R/W/S	200	0~65535	单位 pulse/s
62	减加速度低 16bit	R/W/S	3200	0~65535	单位 pulse/s ²
63	减加速度高 16bit	R/W/S	0	0~65535	单位 pulse/s ²
64	速度低 16bit	R/W/S	1600	0~65535	单位 pulse/s
65	速度高 16bit	R/W/S	0	0~65535	单位 pulse/s
66	加速度低 16bit	R/W/S	3200	0~65535	单位 pulse/s ²
67	加速度高 16bit	R/W/S	0	0~65535	单位 pulse/s ²
68	行程低 16bit	R/W/S	1600	0~65535	单位 pulse
69	行程高 16bit	R/W/S	0	0~65535	单位 pulse
70	运动指令	R/W	0	0~5	触发相应的运动，然后该地址变为 6 0—减速停止 1—正向定长运动 2—反向定长运动 3—正向连续运动 4—反向连续运动 5—立即停止 6—默认值，无意义
71	回零命令	R/W	0	0~2	0—退出回零 1—以正向限位信号为零点回零 2—以负向限位信号为零点回零
72	定长运动工作模式	R/W	0	0/1	0：增量模式 1：绝对模式
73	设备控制寄存器	R/W/S			具体的位定义见 2.2.1
74	回零限位滤波时间	R/W/S	10	0~65535	1 表示 50us
75	设备状态寄存器	R			具体的位定义见 2.2.2
90	保存参数	R/W	0	0/1	读取该地址： 返回 0：保存未完成 返回 1：保存已经完成
91	恢复出厂默认参	R/W	0	0/1	写入 1 启动清除；

	数				读取该地址： 返回 0：清除未完成 返回 1：清除已经完成
92~150	预留	R			预留
位定义	名称说明		默认数值	描述	
7~15	预留		0	无	
6	I0 触发运动使能 (一般默认 IN1 是触发端口)		0	0——触发端口无作用 1——触发端口可以触发运动	
2~5	预留		0	无	
1	负限位信号电平 (一般默认 IN3 是负限位)		1	0—光耦关断时发生负限位 1—光耦导通时发生负限位	
0	正限位信号电平 (一般默认 IN2 是正限位)		1	0—光耦关断时发生正限位 1—光耦导通时发生正限位	

6.2.2 驱动器状态寄存器

位定义	名称说明	默认数值	说明
8~15	保留	0	保留
7	运动完成	1	1——内部脉冲发送完成 0——内部脉冲未完成
6	保留	0	0
5	负限位	0	0——无负限位信号 1——有负限位信号
4	正限位	0	0——无正限位信号 1——有正限位信号
2~3	保留	0	
1	过压	0	0——无过压 1——发生过压
0	过流	0	0——无过流 1——发生过流

6.3 回零功能

6.3.1 以正向限位信号为零点回零

对寄存器地址71（回零命令）写入“1”后回零过程如下：

第一步：以62~67 寄存器地址设置的速度与加速度正向运行至正限位。

第二步：检测到正限位信号后，减速停止。

第三步：以寄存器地址60（回零速度）设置的速度负方向运行至限位信号。

过程如下图：

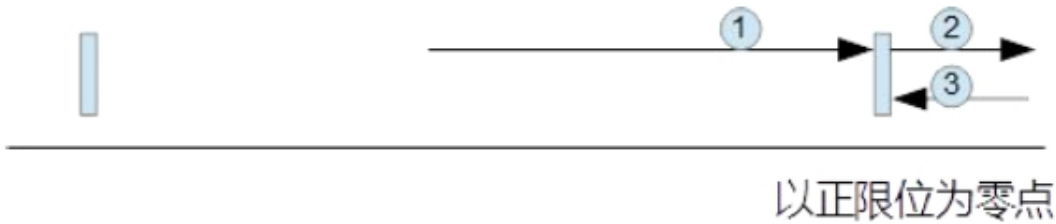

6.3.2 以负向限位信号为零点回零

对寄存器地址71（回零命令）写入“2”后回零过程如下：

第一步：以62~67 寄存器地址设置的速度与加速度负向运行至负限位。

第二步：检测到负限位信号后，减速停止。

第三步：以寄存器地址60（回零速度）设置的速度正方向运行至限位信号。

过程如下图：



6.3.3 退出回零：

对寄存器地址71（回零命令）写入“0”后驱动器退出回零过程，减速停止。

在完成回零后，客户根据需要（如在绝对位置模式下），在寄存器地址40写入1可以清除脉冲计数器。

6.4 MODBUS 常用功能码

6.4.1 读保持寄存器命令 0x03

主机->从机数据

设备地址	功能码	寄存器地址		读寄存器个数		CRC校验	
01	03	00	00	00	01	85	0A

从机->主机数据

设备地址	功能码	返回字节数	寄存器数数		CRC校验	
01	03	02	0A	8C	BF	41

从机返回电流值（寄存器地址00）为2700mA。

6.4.2 写单个寄存器命令 0x06

主机->从机数据

设备地址	功能码	寄存器地址		写入数据		CRC校验	
01	06	00	40	06	40	8A	4E

从机->主机数据

设备地址	功能码	寄存器地址		写入数据		CRC校验	
01	06	00	40	06	40	8A	4E

对从机的速度低16bit（寄存器地址64）写入1600pulse/s。

6.4.3 写多个寄存器命令 0x10

主机->从机数据

设备地址	功能码	起始地址		写入数量		字节数	写入内容		写入内容		CRC校验	
01	10	00	44	00	02	04	38	80	00	01	3B	24

从机->主机数据

设备地址	功能码	起始地址		写入数量		CRC校验	
01	10	00	44	00	02	01	DD

对从机的行程低16bit（寄存器地址64）写入14464，行程高16bit（寄存器地址65）写入1，即行程总数为80000pulse。

6.5 CRC 校验例程

以下例程通过C 语言计算CRC

```

Uint16 Funct_CRC16(unsigned char * puchMsg, Uint16 DataLen)
{
    Uint16 i,j,tmp;
    Uint16 crcdata=0xFFFF;
    for(i=0;i<DataLen;i++)
    {
        crcdata=(*puchMsg)^crcdata;
    }
}
    
```

```
puchMsg++;  
for(j=0;j<8;j++)  
{  
tmp=crcdata&0x0001;  
crcdata=crcdata>>1;  
if(tmp){  
crcdata=crcdata^0xA001;  
}  
}  
}  
returncrcdata;  
}
```

7 保修及售后服务 /Warranty and after-sales service

请保留好包装箱以便运输、储存或需要退回本公司维修时使用。一年保修期：

Please keep the packing box for transportation, storage or need to return to the company for maintenance. One year warranty period:

来自本驱动器使用一年内因为产品自身的原因造成的损坏，负责保修。

From the use of this drive within one year because of the product itself caused by the damage, responsible for the warranty.

不在保修之列：/Not covered by warranty:

不恰当的接线、电源电压和用户外围配置造成的损坏。/Damage caused by improper wiring, power supply voltage and user peripheral configuration.

无本公司书面授权条件下，用户擅自对产品进行更改。/Without the written authorization of the company, users make changes to the products without authorization.

超出电气和环境的要求使用。/Use beyond electrical and environmental requirements.

驱动器序列编号被撕下或无法辨认。/The drive serial number has been torn off or is unreadable.

外壳被明显破坏。/The outer shell was visibly damaged.

不可抗拒的灾害。/An irresistible disaster. 6.2 售后服务 /Aftersales Service

添加微信或者拨打电话



(+86) 18926788846

Email: Tech@TQKTEC.COM

您拨打电话之前，请先记录以下信息：

Before you call, please record the following information:

故障现象/Fault phenomenon

产品型号和序列号/Product model and serial number

安装日期或者生产日期/Installation date or production date