

TD545-C

三合一步进驱动器使用手册

THREE-AXIS STEP MOTOR DRIVE User's Manual

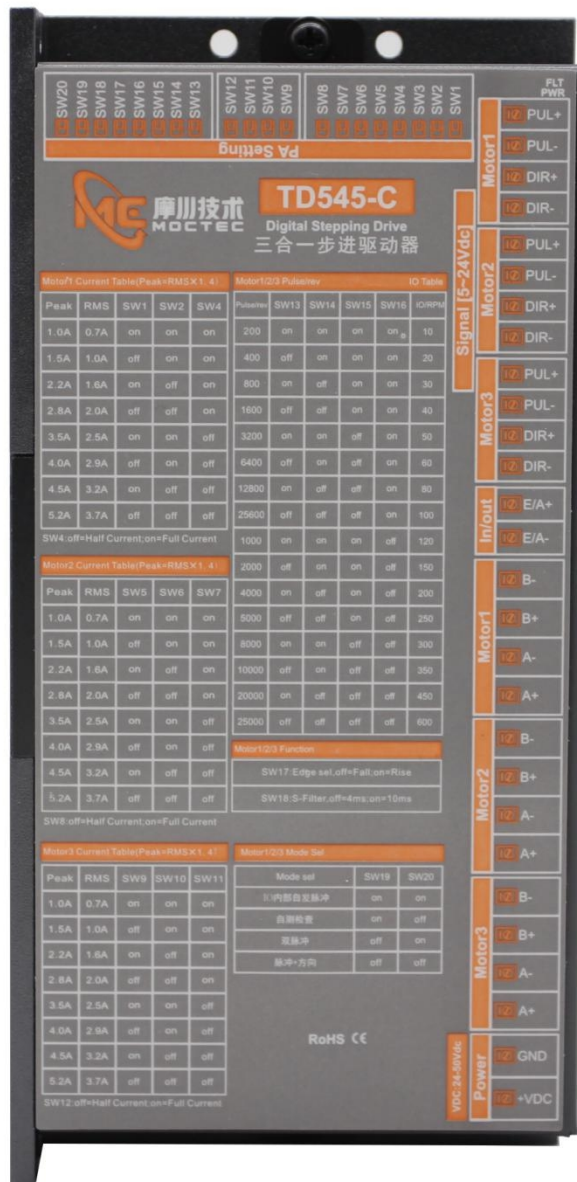

摩川技术(深圳)有限公司

Moschon Technology (Shenzhen) Co., Ltd.

该产品由深圳市泰奇科智能技术有限公司独家发行，版权所有！

目录

前言/Foreword	3
1 概述/Overview	4
1.1 产品介绍/Product Introduction.....	4
1.2 特性/Characteristics.....	4
1.3 应用领域/Application areas.....	5
2 性能指标/Performance Index	5
2.1 电气特性/Electrical characteristics.....	5
2.2 使用环境/Use environment.....	6
3 安装/Installation	6
3.1 安装尺寸/Mounting dimensions.....	6
3.2 安装方法/Installation method.....	7
4 驱动器端口与接线/Driver ports and wiring	7
4.1 接线示意图/Schematic diagram of wiring.....	7
4.2 端口定义/Port Definition.....	8
4.2.2 控制信号输入端口/Control Signal Input Port.....	8
5 拨码定义/Dial definition	14
5.1 电流设定/The current setting.....	14
5.2 细分设定/Subdivision setting.....	15
5.3 功能设置/Function setting.....	16
5.4 参数自整定功能/Parameter self-tuning function.....	16
6 保修及售后服务 /Warranty and after-sales service	17

前言/Foreword

感谢您使用本公司开环步进驱动器。

Thank you for using our open step drive.

在使用本产品前，请务必仔细阅读本手册，了解必要的安全信息、注意事项以及操作方法等。错误的操作可能引发极其严重的后果。

Before using this product, please read this manual carefully to understand the necessary safety information, precautions, and operation methods. Incorrect operation can have extremely serious consequences.

本产品的设计和制造不具备保护人身安全免受机械系统威胁的能力，请用户在机械系统设计和制造过程中考虑安全防护措施，防止因不当的操作或产品异常造成事故。

This product is designed and manufactured without the ability to protect personal safety from mechanical system threats. Users are advised to consider safety precautions during mechanical system design and manufacturing to prevent accidents caused by improper operation or product abnormalities.

由于产品的改进，手册内容可能变更，恕不另行通知。用户对产品的任何改装我公司将不承担任何责任。阅读时，请注意手册中的以下标示：

Due to product improvements, the contents of this manual are subject to change without notice. Our company will not be responsible for any modification of the product by the user.

When reading, please pay attention to the following signs in the manual:



注意：提醒您注意文字中的要点。



小心：表示错误的操作可能导致人身伤害和设备损坏。

本产品经过国家强制 3C 认证，CE 认证，ROHS 认证

This product has passed the national mandatory 3C certification, CE certification, ROHS certification



1 概述/Overview

1.1 产品介绍/Product Introduction

TD545-C 是摩川技术公司新推出的三合一步进驱动器，采用最新 32 位 DSP 数字处理技术，控制算法采用先进的变电流技术和先进的变频技术研发成功，驱动器和电机发热小，电机振动小，运行平稳，体积小，闭环和开环通用。用户可以设置 200-51200 内的细分值，能够满足大多数场合的应用需要。由于采用内置微细分技术，即使在低细分的条件下，也能够达到高细分的效果，低中高速运行都很平稳，噪音超小。驱动器内部集成了参数上电自动整定功能，能够识别我司的混合伺服电机各项参数，针对不同电机自动生成最优运行参数，最大限度发挥电机的性能。

TD545-C is a new THREE-AXIX STEP MOTOR DRIVE introduced by Moschon Technology Company. It adopts the latest 32-bit DSP digital processing technology. The Control Algorithm adopts the advanced variable current technology and the advanced frequency conversion technology. The driver and the motor generate heat small, motor vibration, smooth operation, compact size, closed-loop and open-loop General. USERS can set 200-51200 within the subdivision value, to meet the needs of most applications. Due to the use of built-in micro-subdivision technology, even in the conditions of low subdivision, but also can achieve high subdivision effect, low, medium and high-speed operation is very smooth, ultra-low noise. The driver can identify the parameters of the hybrid servo motor, automatically generate the optimal operating parameters for different motors, and maximize the performance of the motor.

1.2 特性/Characteristics

- 全新 32 位 DSP 技术

New 32 Bit DSP Technology

- 超低振动噪声

Ultra-low vibration noise

- 内置高细分

Built-in high subdivision

- 参数上电自动识别电机参数功能

Automatic parameter power-on setting function

- 变电流控制使电机发热大为降低

Variable current control greatly reduces the heat generation of the motor.

- 静止时电流自动减半

Automatic halving of current at rest

- 可独立驱动三台步进电机

It can drive three stepper motors independently

- 光电隔离差分信号输入

Photoelectric isolation differential signal input

- 脉冲响应频率最高可达 500KHz（出厂默认 200KHz）

Impulse response frequency up to 500KHz (factory default 200KHz)

- 矢量变电流技术，可在 0.7-5.2A 之间设定

Vector variable current technology can be given between 0.7-5.2 A

- 细分设定范围为 200-51200，更高细分可定制

sub-set range 200-51200, higher sub-customizable

- 信号接口电平为 5V 和 24V 电平兼容，无需串联限流电阻

The signal interface level is 5V and 24V compatible without series current limiting resistor

●具有过压、欠压、过流等保护功能

It has the protection functions of overvoltage, undervoltage and overcurrent.

1.3 应用领域/Application areas

适合各种中小型自动化设备和仪器，例如：锂电设备、3C 电子设备、雕刻机、打标机、切割机、激光照排、雕刻机，绘图仪、数控机床、自动装配设备等。在用户期望小噪声、高速度的设备中应用效果特佳。

Suitable for all kinds of small and medium-sized automation equipment and instruments, such as: lithium battery equipment, 3C electronic equipment, engraving machine, marking machine, cutting machine, laser phototypesetting, engraving machine, plotter, CNC machine tool, automatic assembly equipment, etc. It is especially effective in applications where users expect small noise and high speed.

2 性能指标/Performance Index

2.1 电气特性/Electrical characteristics

说明 Explanation	TD545-C			
	最小值 Minimum Value	典型值 Typical Value	最大值 Maximal Value	单位 Unit
连续输出电流 Continuous output current	0.7	-	5.2	A
电源电压（直流） Supply Voltage (DC)	24	24/36	50	Vdc
控制信号输入电流 Control signal input current	6	10	16	mA
控制信号接口电平 Control signal interface level	5	5	24	Vdc
输入信号最小脉冲宽度 Minimum pulse width of input signal	1.5	-	-	uS
步进脉冲频率 Step frequency	0	-	200	KHz
绝缘电阻 Insulation Resistance	100	-	-	MΩ
过压报警值 Overpressure alarm	55			Vdc

2.2 使用环境/Use environment

冷却方式 Cooling Mode		自然冷却或强制风冷 Natural Cooling or forced air cooling
使用环境 Service Environment	场合 Occasion	不能放在其它发热的设备旁，要避免粉尘、油雾、腐蚀性气体，湿度太大及强振动场所，禁止有可燃气体和导电灰尘。 Can not be placed next to other heating equipment, to avoid dust, oil mist, corrosive gases, humidity is too large and strong vibration sites, prohibited combustible gases and conductive dust.
	温度 Temperature	-10℃ ~ +50℃
	湿度 Humidity	40 ~ 90%RH
	振动 Vibration	5.9m/s ² MAX
保存温度 Storage temperature		-20℃~60℃
使用海拔 Use Elevation		1000 米以下 Below 1000 meters
重量 Weight		0.2KG

3 安装/Installation

3.1 安装尺寸/Mounting dimensions

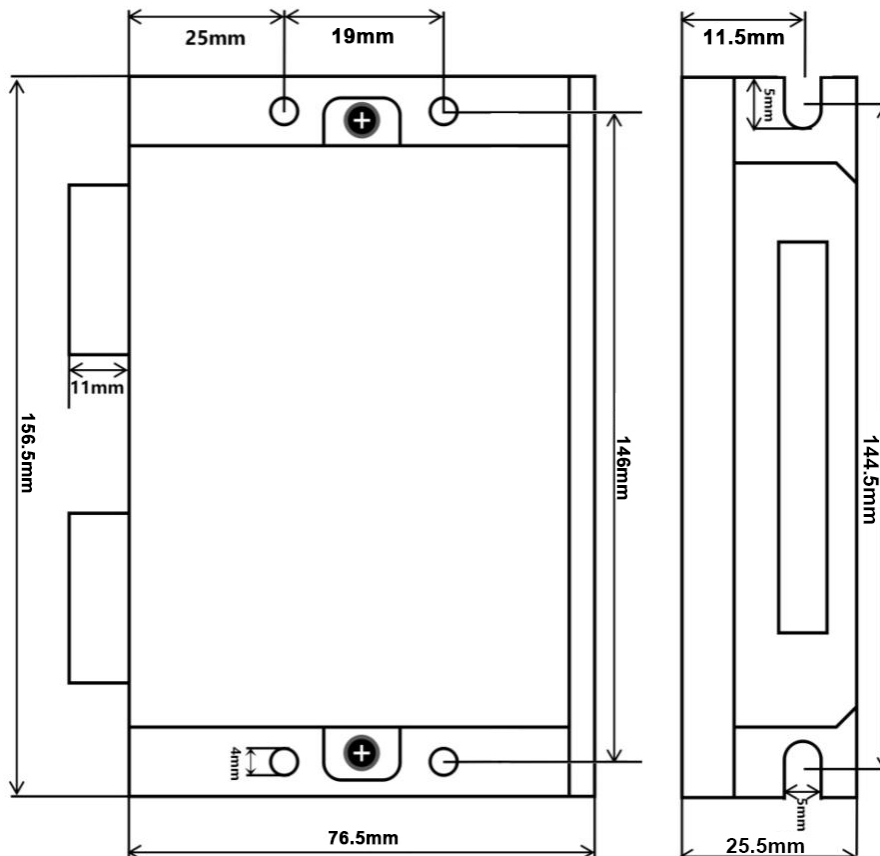

3.2 安装方法/Installation method

驱动器的可靠工作温度通常在 60℃ 以内，电机工作温度为 80℃ 以内。

The reliable operating temperature of the driver is usually within 60℃, and the motor operating temperature is within 80℃.

建议使用时选择自动半流方式，马达停止时电流自动减一半，以减少电机和驱动器的发热。

It is recommended to use the automatic semi-flow mode when using the motor. When the motor stops, the current is automatically reduced by half to reduce the heat of the motor and the drive.

安装驱动器时请采用竖着侧面安装，使散热齿形成较强的空气对流。

Install the drive with vertical side mounting so that the heat dissipating teeth form a strong air convection.

必要时机内靠近驱动器处安装风扇，强制散热，保证驱动器在可靠工作温度范围内工作。

Install a fan near the drive when necessary to force heat dissipation to ensure that the drive works within a reliable operating temperature range.

4 驱动器端口与接线/Driver ports and wiring

4.1 接线示意图/Schematic diagram of wiring

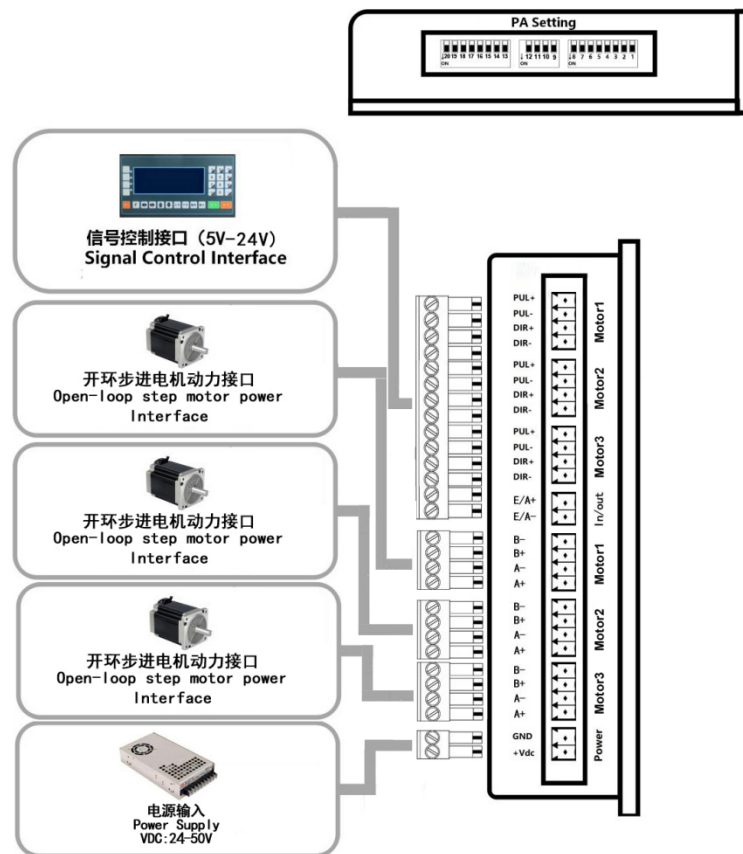





4.2 端口定义/Port Definition

4.2.1 LED 灯状态指示/Lamp status indication

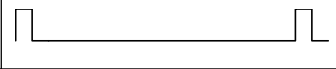
绿色 LED 为电源指示灯，当驱动器接通电源时，该 LED 常亮；当驱动器切断电源时，该 LED 熄灭。红色 LED 为故障指示灯，当出现故障时，该指示灯以 3 秒钟为周期循环闪烁；当故障被用户清除时，红色 LED 常灭。红色 LED 在 3 秒钟内闪烁次数代表不同的故障信息，具体关系如下表所示。

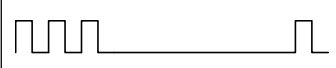
LED power indicator is green, when the drive power, the LED is lit; when the drive power is cut off, the LED is off. Fault indicator red LED, when a failure occurs, the indicator is blinking cycle to cycle 3 seconds; the user when the fault is cleared, the red LED is off. Red LED flashing number within 3 seconds represent different fault information, the specific relationship shown in the following table.

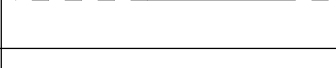
序号 No.	闪烁次数 The number of flashes	红色 LED 闪烁波形 Red LED flashes waveform	故障说明 Description of the problem
1	1		过流故障 (I 峰值 $\geq 25A$) Overcurrent fault (I peak $\geq 25A$)
2	2		过压故障 (Vdc $\geq 55V$) Overvoltage fault (Vdc $\geq 55V$)
3	3		无定义 No definition
4	4		电机开路或接触不良故障 Motor open circuit or the poor contact failure
5	7		无定义 No definition

4.2.2 控制信号输入端口/Control Signal Input Port

控制信号接口

Control Signal interface

驱动器 Drive	信号名称 Signal name	功能说明 Function description
	PUL1+	Motor 1 电机驱动器脉冲信号：脉冲上升沿有效；PUL 高电平时 5V 和 24V 兼容（无需串联限流电阻），低电平时 0~0.5V。为了可靠响应脉冲信号，脉冲宽度应大于 1.5 μs 。
	PUL1-	Motor 1 Motor driver pulse signal: Pulse rising edge effective; Pul high level 5V and 24V compatibility (without series current limiting resistance), low level 0 ~ 0.5 v. In order to respond reliably to the pulse signal, the pulse width should be greater than 1.5 s.

Signal	DIR1+	Motor 1 电机驱动器方向信号：高/低电平信号，为保证电机可靠换向，方向信号应先于脉冲信号至少 $2\mu s$ 建立。DIR 高电平时 5V 和 24V 兼容（无需串联限流电阻），低电平时 $0\sim 0.5V$ 。
	DIR1-	Motor 1 Motor driver direction signal: high/low level signal, in order to ensure reliable Motor commutation, the direction signal should be established at least 2 seconds before the pulse signal. Dir High Level 5V and 24V compatibility (no series current limiting resistance), low level $0 \sim 0.5 v$.
	PUL2+	Motor 2 电机驱动器脉冲信号：脉冲上升沿有效；PUL 高电平时 5V 和 24V 兼容（无需串联限流电阻），低电平时 $0\sim 0.5V$ 。为了可靠响应脉冲信号，脉冲宽度应大于 $1.5\mu s$ 。
	PUL2-	Motor 2 Motor driver pulse signal: Pulse rising edge effective; Pul high level 5V and 24V compatibility (without series current limiting resistance), low level $0 \sim 0.5 v$. In order to respond reliably to the pulse signal, the pulse width should be greater than $1.5 \mu s$.
	DIR2+	Motor 2 电机驱动器方向信号：高/低电平信号，为保证电机可靠换向，方向信号应先于脉冲信号至少 $2\mu s$ 建立。DIR 高电平时 5V 和 24V 兼容（无需串联限流电阻），低电平时 $0\sim 0.5V$ 。
	DIR2-	Motor 2 Motor driver direction signal: high/low level signal, in order to ensure reliable Motor commutation, the direction signal should be established at least 2 seconds before the pulse signal. Dir High Level 5V and 24V compatibility (no series current limiting resistance), low level $0 \sim 0.5 v$.
	PUL3+	Motor 3 电机驱动器脉冲信号：脉冲上升沿有效；PUL 高电平时 5V 和 24V 兼容（无需串联限流电阻），低电平时 $0\sim 0.5V$ 。为了可靠响应脉冲信号，脉冲宽度应大于 $1.5\mu s$ 。
	PUL3-	Motor 3 Motor driver pulse signal: Pulse rising edge effective; Pul high level 5V and 24V compatibility (without series current limiting resistance), low level $0 \sim 0.5 v$. In order to respond reliably to the pulse signal, the pulse width should be greater than $1.5 \mu s$.
	DIR3+	Motor 3 电机驱动器方向信号：高/低电平信号，为保证电机可靠换向，方向信号应先于脉冲信号至少 $2\mu s$ 建立。DIR 高电平时 5V 和 24V 兼容（无需串联限流电阻），低电平时 $0\sim 0.5V$ 。
	DIR3-	Motor 3 Motor driver direction signal: high/low level signal, in order to ensure reliable Motor commutation, the direction signal should be established at least 2 seconds before the pulse signal. Dir High Level 5V and 24V compatibility (no series current limiting resistance), low level $0 \sim 0.5 v$.

	E/A+	<p>Motor 1、Motor 2、Motor3 电机驱动器共用一个使能(脱机)信号：此输入信号用于使能或脱机。E/A+ 接 5V 和 24V（无需串联限流电阻），E/A-接低电平（或内部光耦导通）时，两个驱动器都将切断电机各相的电流使各个电机均处于自由状态，此时步进脉冲不被响应。当不需用此功能时，使能信号端悬空即可。</p> <p>该接口有功能复用：</p> <p>Motor 1、Motor2、Motor 3 驱动器共一路报警输出，只要有其中一路出现报警，均有输出信号，输出方式为 OC 输出，ALM+需要外接上拉电阻，最大上拉电压为直流 24Vdc，上拉电阻 2KΩ，最大输出电流为 50mA。</p>
	ENA-	<p>Motor 1、 Motor 2、 Motor 3 Motor drivers share an enabling signal: This input signal is used to enable or disable. When ENA + connected to 5V and 24V (without series current limiting resistance) , ENA-connected to low level (or internal optocoupler on) , both drivers will cut off the current of each phase of the motor and make each motor in free state, when the step pulse is not responding. When this function is not needed, the signal can be suspended.</p> <p>Motor 1、 Motor 2、 Motor 3 drivers have one alarm output, as long as there is an alarm all the way, there is an output signal, the output mode is OC output, ALM + requires external pull-up resistor, the maximum pull-up voltage is DC 24VDC, pull-up resistor 2K, the maximum output current is 50mA.</p>

控制信号接口电路

A control signal interface circuit

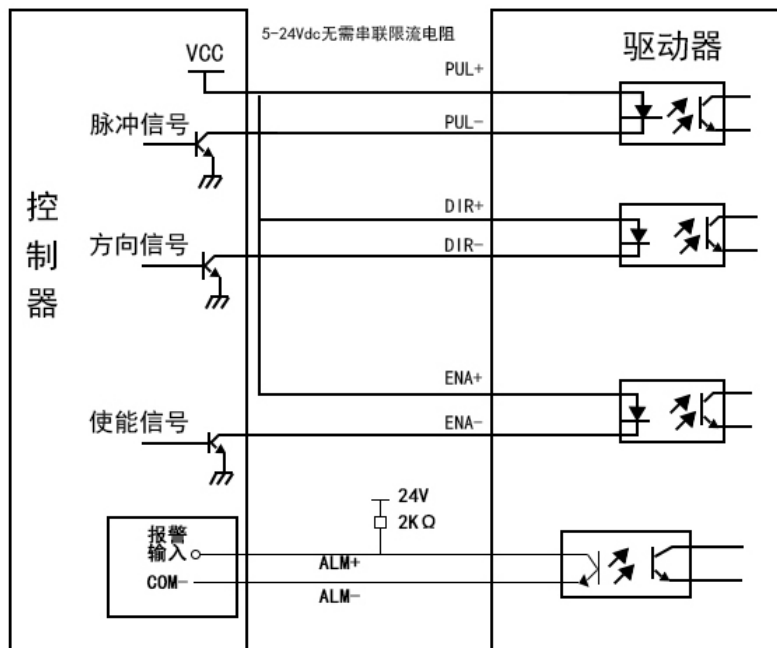
共阳极接法

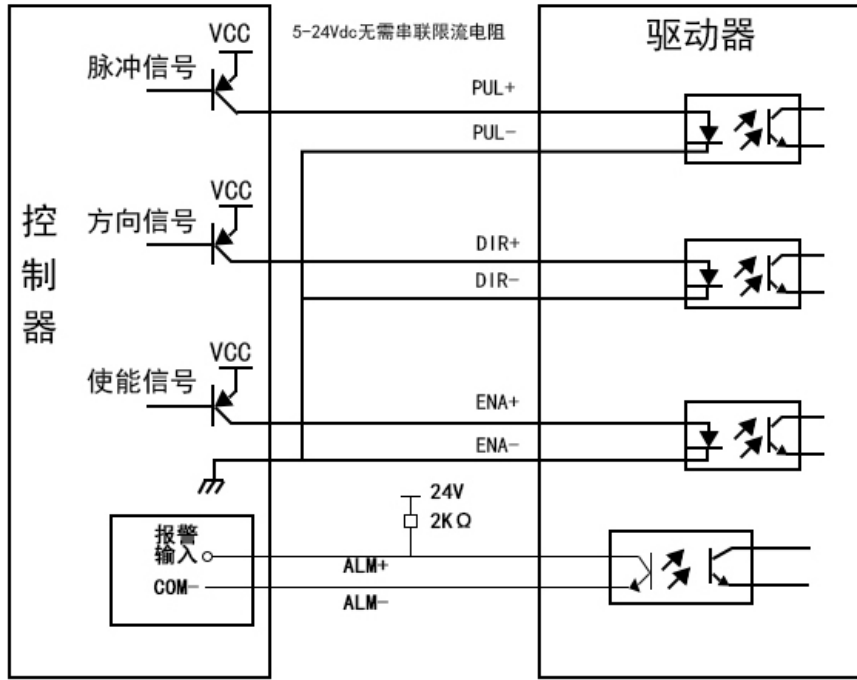

共阴极接法

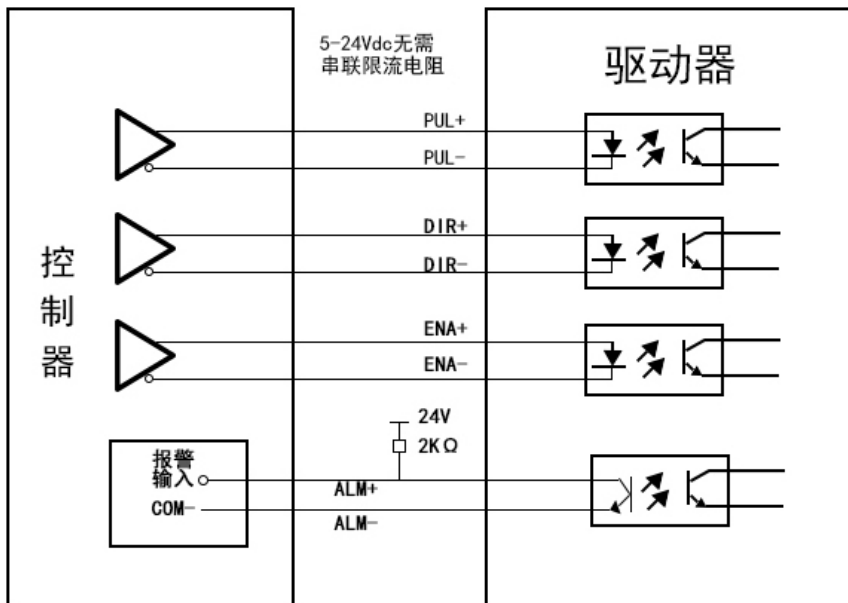

差分方式控制信号接口接线图

控制信号时序图

A control signal timing in FIG.

为了避免一些误动作和偏差，PUL-、DIR-和 ENA-应满足一定要求，如下图所示：

In order to avoid malfunctions and deviations, PUL-, DIR- ENA- should meet certain requirements, and, as shown below:

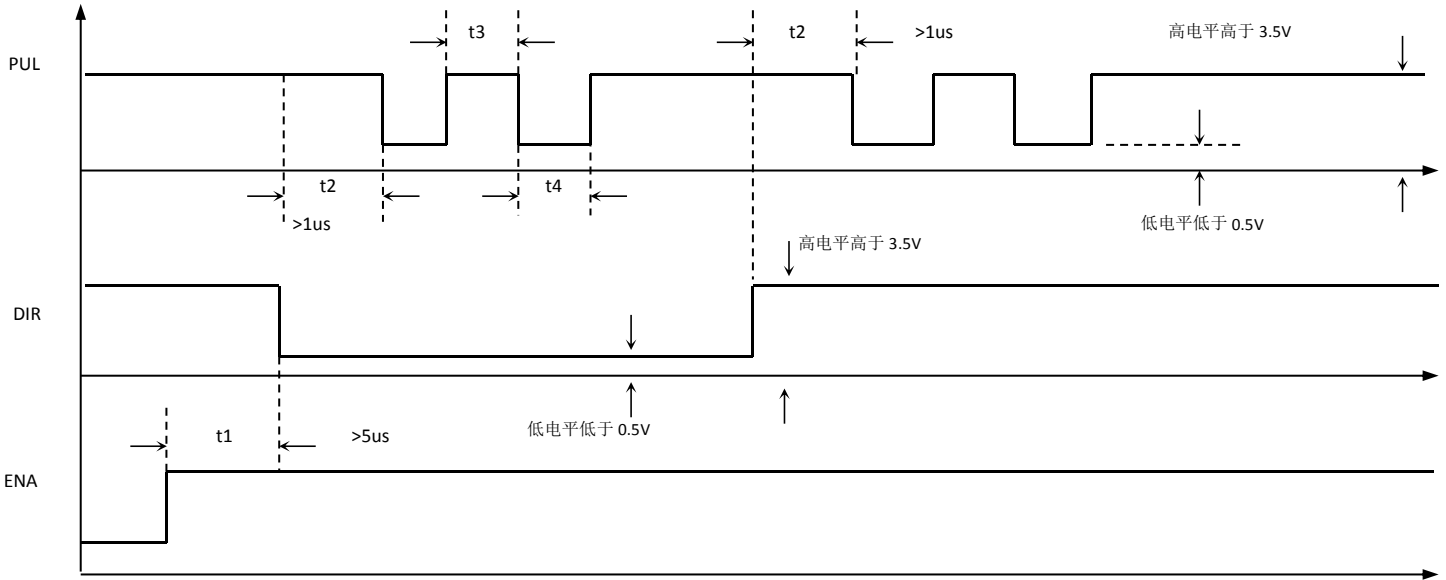

注释/Comment:

t1: ENA (使能信号) 应提前 DIR 至少 5 μs, 确定为高。一般情况下建议悬空即可;

t1: ENA (enable signal) DIR should advance at least 5 μs, determined to be high. In general recommendations can be suspended;

t2: DIR 至少提前 PUL 下降沿 1 μs 确定其状态高或低;

t2: DIR PUL falling 1 μs determined in advance of at least a high or low state;

t3: 脉冲宽度至少不小于 1.5 μs;

t3: at least a pulse width of not less than 1.5 us;

t4: 低电平宽度不小于 1.5 μs。

t4: low level width not less than 1.5 μs.

4.2.3 电源及电机输出端口/Output ports of power supply and motor

供电与电机动力接口

Power supply and motor power interface

驱动器 Drive	名称 Name	功能 Features
Motor 1	A+、A-	Motor 1 的电机 A 相线圈接口。 Motor 1 Motor a phase coil interface.
	B+、B-	Motor 1 的电机 B 相线圈接口。 Motor 1 Motor B phase coil interface.
Motor 2	A+、A-	Motor 2 的电机 A 相线圈接口。 Motor 2 Motor a phase coil interface.
	B+、B-	Motor 2 的电机 B 相线圈接口。 Motor 2 Motor B phase coil interface.

Motor 3	A+、A-	Motor 3 的电机 A 相线圈接口。 Motor 3 Motor a phase coil interface.
	B+、B-	Motor 3 的电机 B 相线圈接口。 Motor 3 Motor B phase coil interface.
Voltage	+VDC	驱动器电源正极输入接口，直流电压 24~50Vdc 输入，推荐 24 或 36Vdc 供电，供电电源输出能力要求 12A 以上。推荐使用线性稳压电源供电。如果是开关电源供电，开关电源输出功率要大于驱动器输入功率，否则开关电源容易保护或烧坏。 Driver power positive input interface, DC voltage 24 ~ 50VDC input, recommended 24 or 36VDC power supply, power supply output capacity requirements 12A above. LINEAR regulated power supply is recommended. If the power supply is switching power supply, switching power supply output power to be greater than the driver input power, otherwise switching power supply easy to protect or burn out.
	GND	驱动器电源负极输入接口。 Driver power supply negative input interface.

电源电压在规定范围之间都可以正常工作，驱动器最好采用非稳压型直流电源供电，也可以采用变压器降压+桥式整流+电容滤波。但注意应使整流后电压纹波峰值不超过其规定的最大电压。建议用户使用低于最大电压的直流电压供电，避免电网波动超过驱动器电压工作范围。

The power supply voltage can work normally between the specified ranges. The driver is preferably powered by an unregulated DC power supply, or a transformer buck + bridge rectifier + capacitor filter. Note, however, that the peak voltage ripple after rectification should not exceed its specified maximum voltage. It is recommended that the user supply power with a DC voltage lower than the maximum voltage to prevent the grid from fluctuating beyond the operating range of the driver voltage.

如果使用稳压型开关电源供电，应注意开关电源的输出电流范围需设成最大。

If using a regulated switching power supply, be aware that the output current range of the switching power supply must be set to maximum.

请注意：

Please note:

接线时要注意电源正负极切勿反接；

When wiring, pay attention to the positive and negative poles of the power supply, do not reverse connection;

最好用非稳压型电源；

It is better to use an unstable power supply;

采用非稳压电源时，电源电流输出能力应大于驱动器设定电流的 60%即可；

The output capacity of the power supply current should be greater than 60% of the set current of the driver when an unstable power supply is used;

采用稳压开关电源时，电源的输出电流应大于或等于驱动器的工作电流；

When a regulated switching power supply is adopted, the output current of the power supply shall be greater than or equal to the working current of the driver;

为降低成本，两三个驱动器可共用一个电源，但应保证电源功率足够大。

To reduce costs, two or three drives can share a power supply, but the power supply should be large enough.

5 拨码定义/Dial definition

5.1 电流设定/The current setting

TD545-C 三合一开环步进驱动器的 Motor 1、Motor 2、Motor 3 统一采用拨码设定电流和细分，设定得到的电流值和细分值两个驱动器是一样的，如果需要两个驱动器的电流值或细分值不一样，请与我司联系，可以为其提供两台驱动器不同的电流值和细分值。拨码电流和细分详细描述如下：

TD545-C THREE-AXIX STEP MOTOR DRIVE Motor 1 and Motor 2 and Motor 3 drives use the dial code to set the current and the subdivision, if you need two drives with different current value or subdivision value, please contact us, we can provide two drives with different current value and subdivision value. The dial current and breakdown are described in detail as follows:

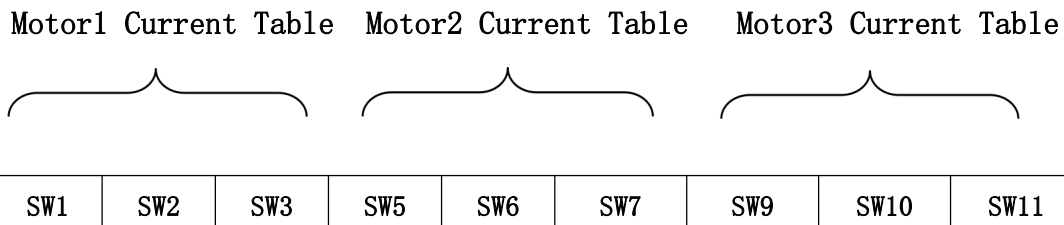

Motor1 Current Table (Peak=RMS×1.4) (驱动器一设定电流表)

Peak	RMS	SW1	SW2	SW3
1.00A	0.7A	on	on	on
1.46A	1.0A	off	on	on
2.20A	1.57A	on	off	on
2.70A	1.93A	off	off	on
3.50A	2.5A	on	on	off
4.00A	2.85A	off	on	off
4.50A	3.21A	on	off	off
5.20A	3.71A	off	off	off

SW4 为半流功能，当 SW4=off 时，为半流设定，当 SW4=on 时，电流静止状态为全流锁轴

SW4 is a half-current function, when SW4 = off, for half-current settings, when SW4 = on, current static state for full-current lock axis

Motor2 Current Table (Peak=RMS×1.4) (驱动器二设定电流表)

Peak	RMS	SW5	SW6	SW7
1.00A	0.7A	on	on	on
1.46A	1.0A	off	on	on
2.20A	1.57A	on	off	on
2.70A	1.93A	off	off	on

3.50A	2.5A	on	on	off
4.00A	2.85A	off	on	off
4.50A	3.21A	on	off	off
5.20A	3.71A	off	off	off

SW8 为半流功能，当 SW8=off 时，为半流设定，当 SW8=on 时，电流静止状态为全流锁轴

SW8 is a half-current function, when SW8 = off, for half-current settings, when SW8 = on, current static state for full-current Lock Axis

Motor3 Current Table (Peak=RMS×1.4) (驱动器三设定电流表)

Peak	RMS	SW9	SW10	SW11
1.00A	0.7A	on	on	on
1.46A	1.0A	off	on	on
2.20A	1.57A	on	off	on
2.70A	1.93A	off	off	on
3.50A	2.5A	on	on	off
4.00A	2.85A	off	on	off
4.50A	3.21A	on	off	off
5.20A	3.71A	off	off	off

SW12 为半流功能，当 SW8=off 时，为半流设定，当 SW8=on 时，电流静止状态为全流锁轴

SW12 is a half-current function, when SW8 = off, for half-current settings, when SW8 = on, current static state for full-current Lock Axis

注：如上电流为标准产品 TD545-C 电流，其它电流可以根据客户需求派生，能设定的电流范围为 0.3-5.2A 之间的任意值。

Note: If the current is standard product TD545-C current, other current can be derived according to customer demand, can set the current range between 0.3-5.2 a arbitrary value.

5.2 细分设定/Subdivision setting

Motor1/2/3 Pulse/red and IO Table (驱动器一和驱动器二和驱动器三共用拨码设定细分和自发脉冲的速度)

Pulse/rew	SW13	SW14	SW15	SW16	IO/RPM
200	on	on	on	on	10
400	off	on	on	on	20
800	on	off	on	on	30
1600	off	off	on	on	40
3200	on	on	off	on	50
6400	off	on	off	on	60
12800	on	off	off	on	80

25600	off	off	off	on	100
1000	on	on	on	off	120
2000	off	on	on	off	150
4000	on	off	on	off	200
5000	off	off	on	off	250
8000	on	on	off	off	300
10000	off	on	off	off	350
20000	on	off	off	off	450
25000	off	off	off	off	600

注：如上细分为标准产品 TD545-C 细分，其它细分可以根据客户需求派生，能设定的细分范围为 200~51200 之间的任意值。

Note: The above subdivides into the standard product TD545-C subdivides, other subdivides may according to the customer demand derivation, can set subdivides the scope between 200-51200 any value.

5.3 功能设置/Function setting

Motor1/2/3 Function

SW17:Edge sel, off=Fall (下降沿有效/Falling Edge is valid) ;on=Rtse (上升沿/Rising Edge)

SW18:S-Filter, off=4ms (高响应) ;on=10ms (低振动)

Motor1/2/3 Mode Sel

Mode sel	SW19	SW20
IO 内部自发脉冲 Io internal spontaneous pulse	on	on
自测检查 Self-test check	on	off
双脉冲 Double Pulse	off	on
脉冲+方向 Pulse, Direction	off	off

5.4 参数自整定功能/Parameter self-tuning function

驱动器为开环步进驱动时，驱动器能上电自动匹配电机参数。注意此时不能输入脉冲，方向信号也不应变化，使能信号不能接入。

When the driver is open-loop step-by-step drive, the driver can power up to match the motor parameters automatically. Note that at this time can not input pulse, direction signal should not change, so that the signal can not access.

6 保修及售后服务 /Warranty and after-sales service

请保留好包装箱以便运输、储存或需要退回本公司维修时使用。一年保修期：

Please keep the packing box for transportation, storage or need to return to the company for maintenance. One year warranty period:

来自本驱动器使用一年内因为产品自身的原因造成的损坏，负责保修。

From the use of this drive within one year because of the product itself caused by the damage, responsible for the warranty.

不在保修之列：/Not covered by warranty:

不恰当的接线、电源电压和用户外围配置造成的损坏。/Damage caused by improper wiring, power supply voltage and user peripheral configuration.

无本公司书面授权条件下，用户擅自对产品进行更改。/Without the written authorization of the company, users make changes to the products without authorization.

超出电气和环境的要求使用。/Use beyond electrical and environmental requirements.

驱动器序列编号被撕下或无法辨认。/The drive serial number has been torn off or is unreadable.

外壳被明显破坏。/The outer shell was visibly damaged.

不可抗拒的灾害。/An irresistible disaster. 6.2 售后服务 /Aftersales Service

添加微信或者拨打电话



(+86) 18926788846

Email: Tech@TQKTEC.COM

您拨打电话之前，请先记录以下信息：

Before you call, please record the following information:

故障现象/Fault phenomenon

产品型号和序列号/Product model and serial number

安装日期或者生产日期/Installation date or production date