

XV8A

数显脉冲低压无刷伺服驱动器使用手册

Low Voltage brushless Servo Drive User's Manual



摩川技术(深圳)有限公司

Moschon Technology (Shenzhen) Co. , Ltd.

该产品由深圳市泰奇科智能技术有限公司独家发行，版权所有！

目录

前言/Foreword.....	3
1 概述/Overview.....	3
1.1 产品介绍/Product Introduction.....	4
1.2 特性/Characteristics.....	4
1.3 应用领域/Application areas.....	5
2 性能指标/Performance Index.....	5
2.1 电气特性/Electrical characteristics.....	5
2.2 使用环境/Use environment.....	5
3 安装/Installation.....	5
3.1 安装尺寸/Mounting dimensions.....	5
3.2 安装方法/Installation method.....	6
4 驱动器端口与接线/Driver ports and wiring.....	7
4.1 接线示意图/Schematic diagram of wiring.....	7
4.2 端口定义/Port Definition.....	8
5 拨码定义/Dial definition.....	13
5.1 细分设定/Subdivision setting.....	14
5.2 功能设置/Function setting.....	14
5.3 参数自整定功能/Parameter self-tuning function.....	135
6 保修及售后服务 /Warranty and after-sales service.....	16

前言/Foreword

感谢您使用本公司开环步进驱动器。

Thank you for using our open step drive.

在使用本产品前，请务必仔细阅读本手册，了解必要的安全信息、注意事项以及操作方法等。错误的操作可能引发极其严重的后果。

Before using this product, please read this manual carefully to understand the necessary safety information, precautions, and operation methods. Incorrect operation can have extremely serious consequences.

本产品的设计和制造不具备保护人身安全免受机械系统威胁的能力，请用户在机械系统设计和制造过程中考虑安全防护措施，防止因不当的操作或产品异常造成事故。

This product is designed and manufactured without the ability to protect personal safety from mechanical system threats. Users are advised to consider safety precautions during mechanical system design and manufacturing to prevent accidents caused by improper operation or product abnormalities.

由于产品的改进，手册内容可能变更，恕不另行通知。用户对产品的任何改装我公司将不承担任何责任。

阅读时，请注意手册中的以下标示：

Due to product improvements, the contents of this manual are subject to change without notice. Our company will not be responsible for any modification of the product by the user.

When reading, please pay attention to the following signs in the manual:



注意：提醒您注意文字中的要点。



小心：表示错误的操作可能导致人身伤害和设备损坏。

本产品经过国家强制 3C 认证，CE 认证，ROHS 认证

This product has passed the national mandatory 3C certification, CE certification, ROHS certification



1 概述/Overview

1.1 产品介绍/Product Introduction

XV8A 是我公司基于十多年数字式低压无刷伺服系统经验研制开发的一款带 LCD 高清屏显示的低压无刷伺服驱动电机产品，本产品采用了最新 DSP 数字处理芯片，LCD 显示屏，先进的变电流算法和变频控制算法技术，为设备制造厂商提供了一种高性价比的高档的步进驱动控制器解决方案。XC88D 外观精美，结构小巧，减低了线间的电磁干扰；采用了抗振动技术和低发热技术，有效的解决了电机和驱动器的发热、振动和噪声等问题。

XV8A is a low-voltage brushless servo motor product with Lcd high-definition display, which is developed by our company based on more than ten years' experience of digital low-voltage brushless servo system, advanced variable current algorithm and variable frequency control algorithm technology, for equipment manufacturers to provide a cost-effective high-grade step-drive controller solutions. XC88D has a beautiful appearance, compact structure, reduce the electromagnetic interference between the lines, using anti-vibration technology and low heating technology, effectively solve the motor and driver heating, vibration and noise problems.

1.2 特性/Characteristics

●工作电压：直流输入电压 24VDC~80VDC，推荐工作电压 24V/36V/48V

Working Voltage: DC INPUT VOLTAGE 24VDC ~ 80VDC, recommended working voltage 24V/36V/48V

●连续输出电流最大值 8.0A

Maximum continuous output current 8.0 A

●可接受差分 and 单端式脉冲/方向/脱机指令

Can Accept Differential and single-ended pulse/direction/offline instructions

●有故障输出指示接口功能

There is function of fault output indicating interface

●带 LCD 高清屏显示相关数据及参数

Display related data and parameters with LCD high definition screen

●每圈脉冲数可通过调试软件或拨码设定（细分）

The number of pulses per cycle can be set by debugging software or code (subdivision)

●具有过压、欠压、过流等保护功能

With over-voltage, under-voltage, over-current and other protection functions

●单/双脉冲模式、脉冲有效沿可选（通过串口连接上位机选择）

Single/double pulse mode, pulse effective edge optional (via serial connection to host computer)

●脉冲响应频率最高可达 500KHz（出厂默认 200KHz）

Impulse response frequency up to 500KHz (factory default 200KHz)

●脉冲，方向和脱机信号输入接口电平为5-24V兼容

Pulse, direction and off-line signal input interface levels are 5-24V compatible

●具有 USB 串口 TTL 电平（RS232 MODEL BUS 协议）调试功能，但需使用本公司专用的串口调试线
With USB serial TTL level (RS232 MODEL BUS protocol) debugging function, but need to use the company's dedicated serial debugging line

1.3 应用领域/Application areas

适合各种中小型自动化设备和仪器，例如：锁螺丝机，剥线机，绕线机，端子机，激光机，喷绘机、中小型雕刻机、电子加工设备、自动抓取设备、专用数控机床、包装设备和机器人等。在用户期望低噪声、高速度的设备中应用效果尤佳。

Suitable for all kinds of small and medium-sized automation equipment and instruments, such as: lock screw machine, wire stripping machine, winding machine, terminal machine, laser machine, printing machine, medium and small-sized engraving machine, electronic processing equipment, automatic grab equipment, special CNC machine tools, packaging equipment and robots. It works especially well on devices that users expect to have low noise and high speed.

2 性能指标/Performance Index

2.1 电气特性/Electrical characteristics

说明 Explanation	XV8A			
	最小值 Minimum Value	典型值 Typical Value	最大值 Maximal Value	单位 Unit
连续输出电流 Continuous output current	1.0	-	8.0	A
电源电压（直流） Power Supply Voltage (DC)	24	24/36/48	80	Vdc
逻辑输入电流 Logic input current	6	10	16	mA
逻辑输入电压 Logical input voltage	5	5	24	Vdc
脉冲频率 Pulse Frequency	0	200	500	KHz
脉冲高电平宽度 Pulse high width	1.5	-	-	US
绝缘电阻 Insulation Resistance	100	-	-	MΩ
位置误差控制精度 Accuracy of position error control	-	±1	-	PULSE
最高加速度（空载） Maximum acceleration (no load)	-	100	-	RPM/MS
过压保护电压 Overvoltage protection voltage	92			VDC
速度控制精度 Speed control accuracy	-	±2	-	RPM

2.2 使用环境/Use environment

冷却方式 Cooling Mode		自然冷却或强制风冷 Natural Cooling or forced air cooling
使用环境 Service Environment	场合 Occasion	不能放在其它发热的设备旁，要避免粉尘、油雾、腐蚀性气体，湿度太大及强振动场所，禁止有可燃气体和导电灰尘。 Can not be placed next to other heating equipment, to avoid dust, oil mist, corrosive gases, humidity is too large and strong vibration sites, prohibited combustible gases and conductive dust.
	温度 Temperature	-10℃ ~ +50℃
	湿度 Humidity	40 ~ 90%RH
	振动 Vibration	5.9m/s ² MAX
保存温度 Storage temperature		-20℃~60℃
使用海拔 Use Elevation		1000 米以下 Below 1000 meters
重量 Weight		0.2KG

3 安装/Installation

3.1 安装尺寸/Mounting dimensions

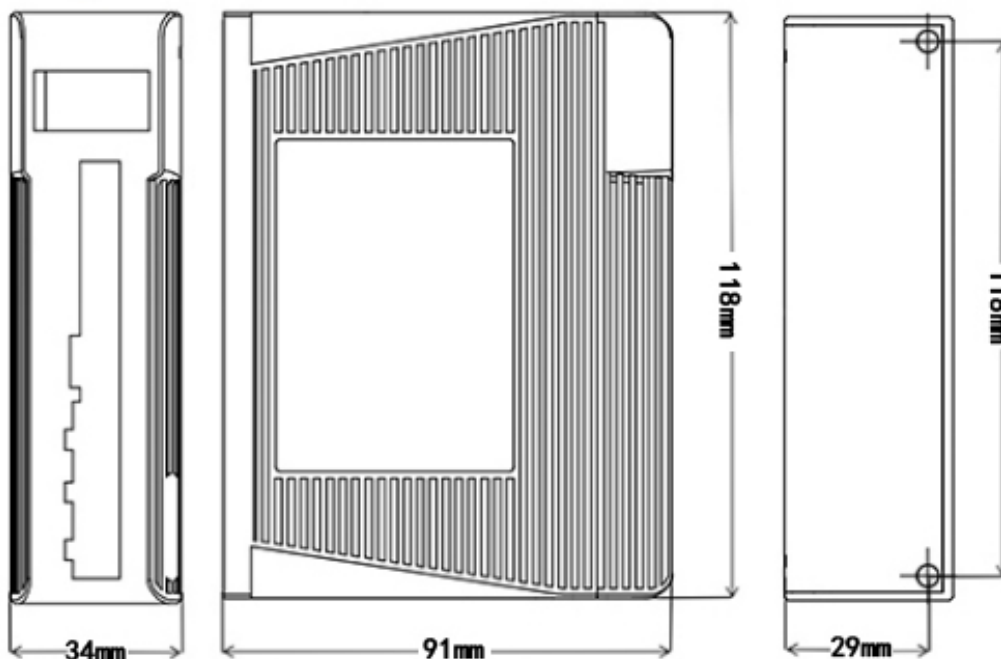

3.2 安装方法/Installation method

驱动器的可靠工作温度通常在 60℃ 以内，电机工作温度为 80℃ 以内。

The reliable operating temperature of the driver is usually within 60℃, and the motor operating temperature is within 80℃.

建议使用时选择自动半流方式，马达停止时电流自动减一半，以减少电机和驱动器的发热。

It is recommended to use the automatic semi-flow mode when using the motor. When the motor stops, the current is automatically reduced by half to reduce the heat of the motor and the drive.

安装驱动器时请采用竖着侧面安装，使散热齿形成较强的空气对流。

Install the drive with vertical side mounting so that the heat dissipating teeth form a strong air convection.

必要时机内靠近驱动器处安装风扇，强制散热，保证驱动器在可靠工作温度范围内工作。

Install a fan near the drive when necessary to force heat dissipation to ensure that the drive works within a reliable operating temperature range.

4 驱动器端口与接线/Driver ports and wiring

4.1 接线示意图/Schematic diagram of wiring

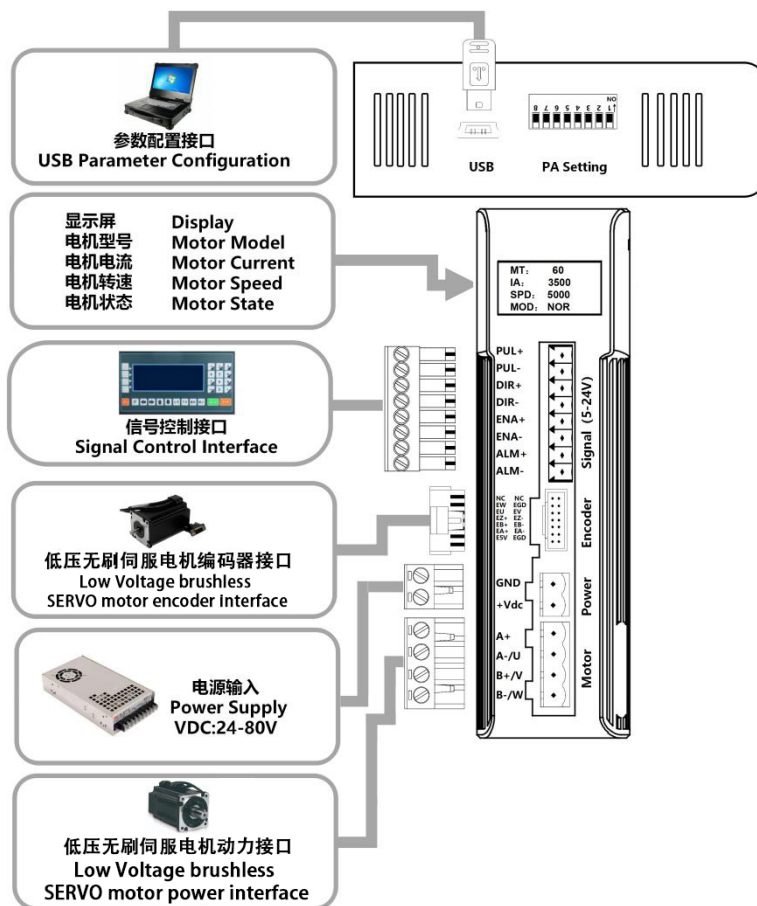

4.2 端口定义/Port Definition

4.2.1 LCD 屏显示及状态指示/LCD Display and status indication

上电后 LCD 屏亮说明驱动器电源正常，当驱动器接通电源时，LCD 屏显示界面会显示公司相关信息，然后跳到正常界面，正常界面一般情况出厂会默认四行数据，如下：

When the driver is connected to the power, the LCD screen display will display the company's relevant information, and then jump to the normal interface, the normal interface will normally default four lines of data factory, as follows:

序号 No.	显示内容 Display content	内容或单位 Content or unit	说明 Account for
1	电机机座 Motor base	TV42/TV57/TV60	闭环电机的机座号显示 Display the machine seat number of the closed-loop motor
2	当前细分 Current subdivision	4000	细分数 Subfraction
3	实时速度 Real-time velocity	RPM	每分钟多少转 How many revolutions per minute
4	算法模式 Algorithmic pattern	FOC/PM/LEAD/全电流	显示当前控制算法 Displays the current control algorithm

4.2.2 控制信号输入端口/Control Signal Input Port

控制信号接口

Control Signal interface

接口名称 Interface name	功能 Features	说明 Explanation
PUL+	脉冲正输入端 Pulse Positive Input	兼容 5V-24V 电平信号 Compatible 5V - 24V level signal
PUL-	脉冲负输入端 Pulse negative input	
DIR+	方向正输入端 Directional Positive Input	
DIR-	方向负输入端 Directional negative input	
ENA+	使能正输入端 Enable Positive Input	
ENA-	使能负输入端 Enable negative input	
ALM+	报警信号正输出端 Positive output of alarm	集电极开路 OC 输出，最大上拉电平 24V，最大输出电流 100mA

	signal	Open collector output, maximum pull up level 24V, maximum output current 100mA
ALM-	报警信号负输出端 Negative output of alarm signal	

控制信号接口电路

A control signal interface circuit

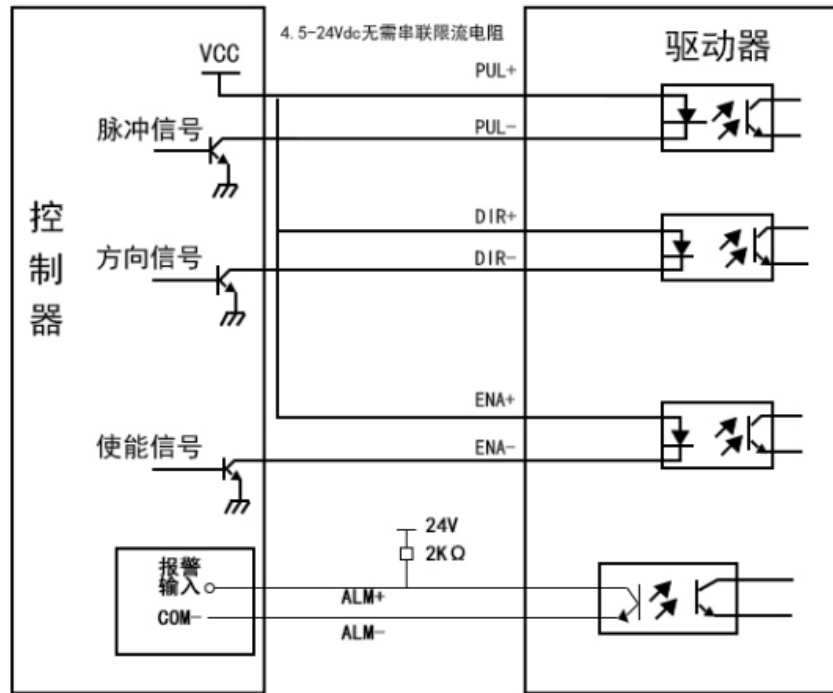
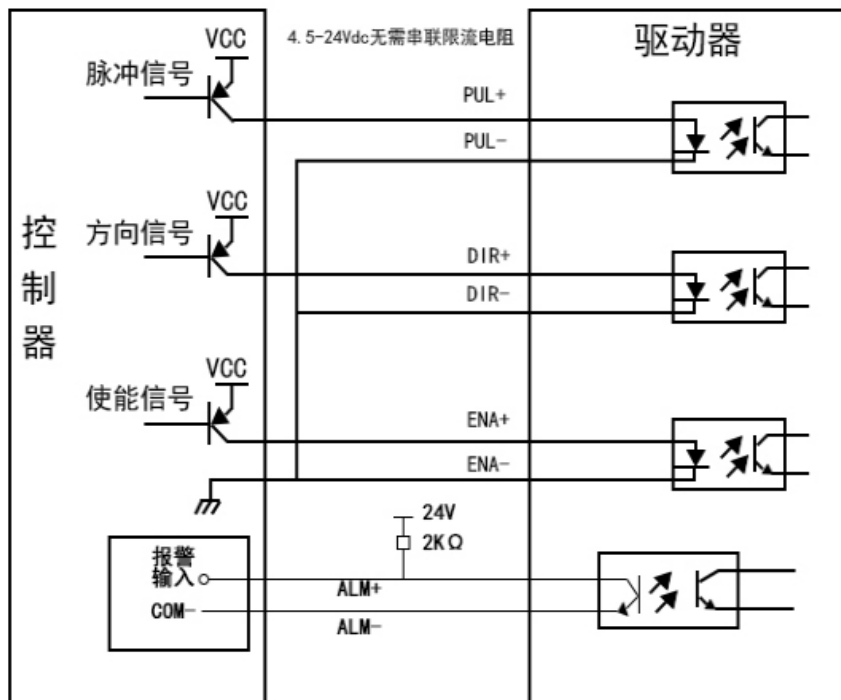
共阳极接法

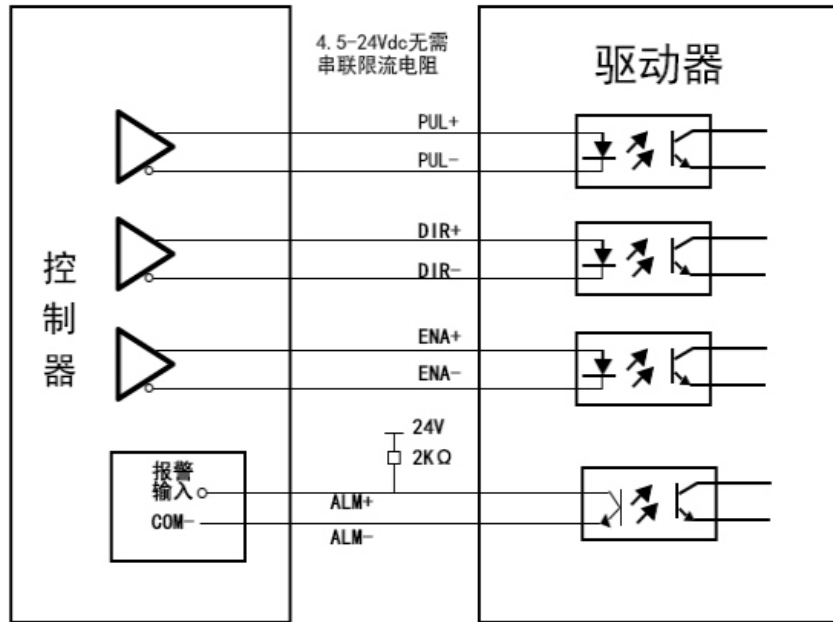
共阴极接法



差分方式控制信号接口接线图

控制信号时序图

A control signal timing in FIG.

为了避免一些误动作和偏差, PUL-、DIR-和 ENA-应满足一定要求, 如下图所示:

In order to avoid malfunctions and deviations, PUL-, DIR- ENA- should meet certain requirements, and, as shown below:

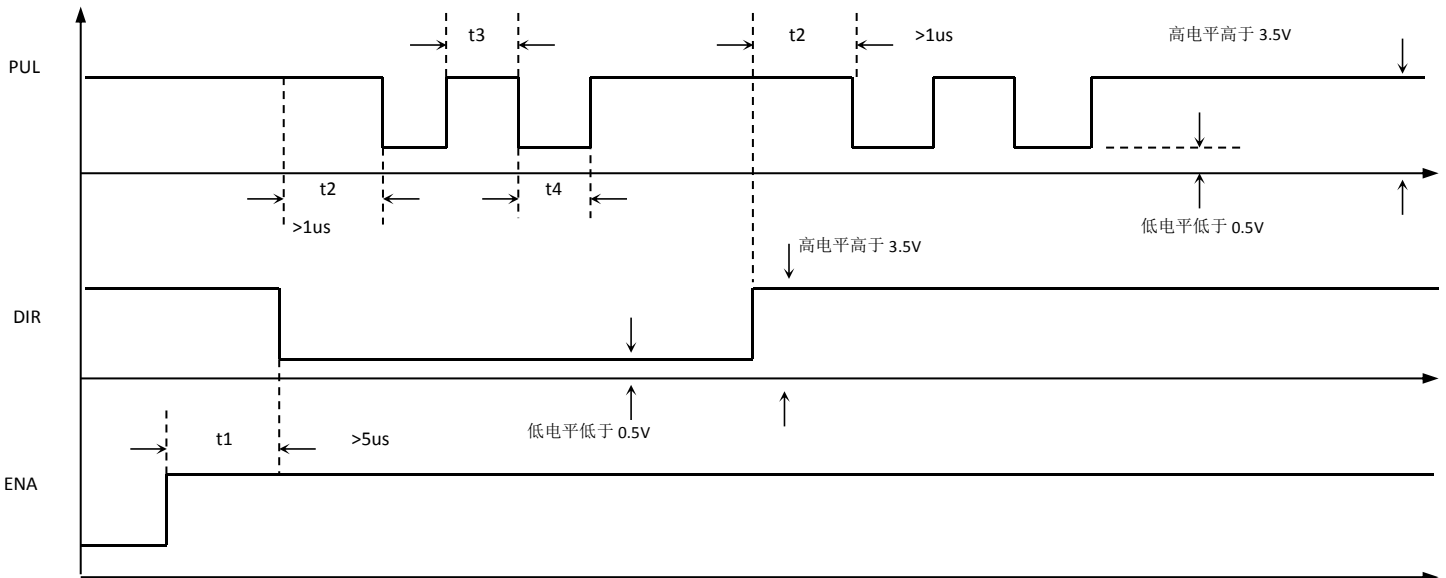

注释/Comment:

t1: ENA (使能信号) 应提前 DIR 至少 $5\mu s$, 确定为高。一般情况下建议悬空即可;

t1: ENA (enable signal) DIR should advance at least $5\mu s$, determined to be high. In general recommendations can be suspended;

t2: DIR 至少提前 PUL 下降沿 $1\mu s$ 确定其状态高或低;

t2: DIR PUL falling $1\mu s$ determined in advance of at least a high or low state;

t3: 脉冲宽度至少不小于 $1.5\mu s$;

t3: at least a pulse width of not less than $1.5\mu s$;

t4: 低电平宽度不小于 $1.5\mu s$ 。

t4: low level width not less than $1.5\mu s$.

4.2.3 编码器输入端口/Encoder input port

接口名称 Interface name	功能 Features
EA+	编码器 A 信号差分输入接口 Encoder a signal differential input interface
EA-	
EB+	编码器 B 信号差分输入接口 Encoder b signal differential input interface
EB-	
EZ+	编码器 B 信号差分输入接口 (编码器没有 Z 信号可以不接) Encoder Z signal differential input interface (The encoder doesn't have a Z signal to ignore)
EZ-	
EU	霍尔 U 信号单端输入, 用于直流伺服电机, 外转子伺服电机, 无刷伺服电机, 混合伺服不用 Houle u signal single input, used for DC servo motor, external rotor servo motor, brushless servo motor, hybrid servo
EV	霍尔 V 信号单端输入, 用于直流伺服电机, 外转子伺服电机, 空心杯伺服电机, 无刷伺服电机, 混合伺服不用 Houle v Signal single input, for DC servo motor, external rotor Servo Motor, Hollow Cup Servo Motor, brushless Servo Motor, hybrid servo
EW	霍尔 W 信号单端输入, 用于直流伺服电机, 外转子伺服电机, 空心杯伺服电机, 无刷伺服电机, 混合伺服不用 Houle W Signal single input, for DC servo motor, external rotor Servo Motor, Hollow Cup Servo Motor, brushless Servo Motor, hybrid servo
E5V	给电机的编码器和霍尔元件提供直流电压 5V, 电流 100mA It supplies the motor's encoder and Houle element with a DC voltage of 5V and a current of 100mA
gnd	5V 参考段负极 5V Reference Negative electrode
gnd	5V 参考段负极 5V Reference Negative electrode
NC	预留本公司内部技术人员使用, 不能外接任何其他电路, 否则烧坏驱动器 Reserved the use of the company's internal technical personnel, can not be external to any other circuit, or burn the drive
NC	预留本公司内部技术人员使用, 不能外接任何其他电路, 否则烧坏驱动器 Reserved the use of the company's internal technical personnel, can not be external to any other circuit, or burn the drive

4.2.4 电源及电机输出端口/Output ports of power supply and motor

供电与电机动力接口

Power supply and motor power interfac

接口名称 Interface name	功能 Features
GND	直流电源地

	DC power source
+VDC	直流电源正极, 供电电压范围: 直流 24-80Vdc, 推荐 24Vdc, 36Vdc, 48Vdc 工作。 DC power positive, supply voltage range: DC 24-80VDC, recommended 24VDC, 36VDC, 48VDC work.
A+	步进电机 A+相绕组接口, 开环步进和混合伺服用到, 直流伺服该接口不用。 The a-phase winding interface of stepper motor, open-loop stepping and hybrid servo are used, but the DC servo interface is not.
A-/U	步进电机 A-相绕组接口或直流伺服 U 相绕组接口 Step Motor a-phase winding interface or DC Servo U phase winding interface
B+/V	步进电机 B+相绕组接口或直流伺服 V 相绕组接口 Step Motor b+phase winding interface or DC Servo V phase winding interface
B-/W	步进电机 B-相绕组接口或直流伺服 W 相绕组接口 Step Motor b-phase winding interface or DC Servo W phase winding interface

USB 串口 RS232-TTL (3.3V) 电平通讯接口
USB serial port RS232-TTL (3.3V) level communication interface

接口名称 Interface name	功能 Function	说明 Account for
+5V	5V 电源正极 5V power supply positive pole	靠近拨码测引脚 Near Dial Pin
TXD	RS232-TTL (3.3V) 发送端 Rs232-TTL (3.3 v) 发送器	
RXD	RS232-TTL (3.3V) 接收端 Rs232-ttl (3.3 v) 接收器	
GND	5V 电源地 5V ground	0V
AIN	外部模拟量 0-5V 输入控制 External Analog 0-5V input control	模拟量电平或电位器 Analog level or potentiometer

电源电压在规定范围之间都可以正常工作, 驱动器最好采用非稳压型直流电源供电, 也可以采用变压器降压+桥式整流+电容滤波。但注意应使整流后电压纹波峰值不超过其规定的最大电压。建议用户使用低于最大电压的直流电压供电, 避免电网波动超过驱动器电压工作范围。

The power supply voltage can work normally between the specified ranges. The driver is preferably powered by an unregulated DC power supply, or a transformer buck + bridge rectifier + capacitor filter. Note, however, that the peak voltage ripple after rectification should not exceed its specified maximum voltage. It is recommended that the user supply power with a DC voltage lower than the maximum voltage to prevent the grid from fluctuating beyond the operating range of the driver voltage.

如果使用稳压型开关电源供电, 应注意开关电源的输出电流范围需设成最大。

If using a regulated switching power supply, be aware that the output current range of the switching power supply must be set to maximum.

请注意:

Please note:

接线时要注意电源正负极切勿反接;

When wiring, pay attention to the positive and negative poles of the power supply, do not reverse connection;

最好用非稳压型电源；

It is better to use an unstable power supply;

采用非稳压电源时，电源电流输出能力应大于驱动器设定电流的 60%即可；

The output capacity of the power supply current should be greater than 60% of the set current of the driver when an unstable power supply is used;

采用稳压开关电源时，电源的输出电流应大于或等于驱动器的工作电流；

When a regulated switching power supply is adopted, the output current of the power supply shall be greater than or equal to the working current of the driver;

为降低成本，两三个驱动器可共用一个电源，但应保证电源功率足够大。

To reduce costs, two or three drives can share a power supply, but the power supply should be large enough.

5 拨码定义/Dial definition

5.1 细分设定/Subdivision setting

Pulse/rew	SW1	SW2	SW3	SW4
Default[400]	on	on	on	on
800	off	on	on	on
1600	on	off	on	on
3200	off	off	on	on
6400	on	on	off	on
12800	off	on	off	on
25600	on	off	off	on
2000	off	off	off	on
3600	on	on	on	off
4000	off	on	on	off
5000	on	off	on	off
7200	off	off	on	off
8000	on	on	off	off
12000	off	on	off	off
20000	on	off	off	off
512000	off	off	off	off

注：如上细分为标准产品 XV8A 细分，其它细分可以根据客户需求派生，能设定的细分范围为 200~51200 之间的任意值。

Note: The above subdivides into the standard product XV8A subdivides, other subdivides may according to the customer demand derivation, can set subdivides the scope between 200-51200 any value.

5.2 功能设置/Function setting

电机初始方向设置/Initial orientation of motor

Direction	SW5	Remark
CCW	Off	正转 Forward rotation
CW	On	反转 Inverts

驱动控制模式设定/Drive control mode setting

Drivecontrolmode	SW6	Remark
FOC	off	矢量闭环控制（丝杆转动） VECTOR CLOSED-LOOP CONTROL (screw rotation)
PM	on	功率角闭环控制（皮带转动） Power Angle closed loop control (belt rotation)

电机尺寸设置/Motor size setting

Motor	SW7	SW8	Remark
TV42	on	on	当 SW7/SW8 设为 off/off 时，可通过软件设定匹配的电机 When SW7/SW8 is set to off/off, the matching motor can be set by software
TV57	off	on	
TV60	on	off	
Default	off	off	

5.3 参数自整定功能/Parameter self-tuning function

驱动器为开环步进驱动时，驱动器能上电自动匹配电机参数。注意此时不能输入脉冲，方向信号也不应变化，使能信号不能接入。

When the driver is open-loop step-by-step drive, the driver can power up to match the motor parameters automatically. Note that at this time can not input pulse, direction signal should not change, so that the signal can not access.

6 保修及售后服务 /Warranty and after-sales service

请保留好包装箱以便运输、储存或需要退回本公司维修时使用。一年保修期：

Please keep the packing box for transportation, storage or need to return to the company for maintenance. One year warranty period:

来自本驱动器使用一年内因为产品自身的原因造成的损坏，负责保修。

From the use of this drive within one year because of the product itself caused by the

damage, responsible for the warranty.

不在保修之列: /Not covered by warranty:

不恰当的接线、电源电压和用户外围配置造成的损坏。/Damage caused by improper wiring, power supply voltage and user peripheral configuration.

无本公司书面授权条件下,用户擅自对产品进行更改。/Without the written authorization of the company, users make changes to the products without authorization.

超出电气和环境的要求使用。/Use beyond electrical and environmental requirements.

驱动器序列编号被撕下或无法辨认。/The drive serial number has been torn off or is unreadable.

外壳被明显破坏。/The outer shell was visibly damaged.

不可抗拒的灾害。/An irresistible disaster. 6.2 售后服务 /Aftersales Service

添加微信或者拨打电话



(+86) 18926788846

Email: Tech@TQKTEC.COM

您拨打电话之前,请先记录以下信息:

Before you call, please record the following information:

故障现象/Fault phenomenon

产品型号和序列号/Product model and serial number

安装日期或者生产日期/Installation date or production date