

IRO42

一体集成式 RS485 开环步进驱动电机使用手册

Integrated RS485 open-loop stepping motor User's Manual



摩川技术(深圳) 有限公司

Moschon Technology (Shenzhen) Co. , Ltd.

该产品由深圳市泰奇科智能技术有限公司独家发行，版权所有！

目录

前言/Foreword	3
1 概述/Overview	4
1.1 产品介绍/Product Introduction.....	4
1.2 特性/Characteristics.....	4
1.3 应用领域/Application areas.....	5
2 性能指标/Performance Index	5
2.1 电气特性/Electrical characteristics.....	5
2.2 适配标准电机/Suitable for standard motor.....	5
2.3 使用环境/Use environment.....	6
3 安装/Installation	6
3.1 安装尺寸/Mounting dimensions.....	6
3.2 安装方法/Installation method.....	8
4 驱动器端口与接线/Driver ports and wiring	8
4.1 接线示意图/Schematic diagram of wiring.....	8
4.2 端口定义/Port Definition.....	9
4.2.2 控制信号输入端口/Control Signal Input Port.....	9
5 拨码定义/Dial definition	11
6 通讯和通讯协议说明/Description of communications and communication protocols	13
6.1 网络布局/Network layout.....	13
6.2 通讯协议/Communication Protocol.....	13
6.3 回零功能/Return to zero function.....	16
6.4 MODBUS 常用功能码/MODBUS common function code.....	17
6.5 CRC 校验例程/CRC check routine.....	18
7 保修及售后服务 /Warranty and after-sales service	18

前言/Foreword

感谢您使用本公司开环步进驱动器。

Thank you for using our open step drive.

在使用本产品前，请务必仔细阅读本手册，了解必要的安全信息、注意事项以及操作方法等。错误的操作可能引发极其严重的后果。

Before using this product, please read this manual carefully to understand the necessary safety information, precautions, and operation methods. Incorrect operation can have extremely serious consequences.

本产品的设计和制造不具备保护人身安全免受机械系统威胁的能力，请用户在机械系统设计和制造过程中考虑安全防护措施，防止因不当的操作或产品异常造成事故。

This product is designed and manufactured without the ability to protect personal safety from mechanical system threats. Users are advised to consider safety precautions during mechanical system design and manufacturing to prevent accidents caused by improper operation or product abnormalities.

由于产品的改进，手册内容可能变更，恕不另行通知。用户对产品的任何改装我公司将不承担任何责任。阅读时，请注意手册中的以下标示：

Due to product improvements, the contents of this manual are subject to change without notice. Our company will not be responsible for any modification of the product by the user.

When reading, please pay attention to the following signs in the manual:



注意：提醒您注意文字中的要点。



小心：表示错误的操作可能导致人身伤害和设备损坏。

本产品经过国家强制 3C 认证，CE 认证，ROHS 认证

This product has passed the national mandatory 3C certification, CE certification, ROHS certification



1 概述/Overview

1.1 产品介绍/Product Introduction

IR042 是我公司新推出的数字式一体集成 RS485 控制的驱动电机，驱动器采用 32 位 DSP 数字处理技术，变电流技术，低发热技术等技术设计完成，具有低振动，运行平稳，低发热，高可靠性等优点。用户可以通过 RS485 进行对驱动电机的控制，能够满足大多数场合的应用需要。低中高速运行都很平稳，噪音超小。驱动器内部集成了上电自动适应电机的功能，能够针对不同电机自动生成最优运行参数，最大限度发挥电机的性能。

IR042 is a new introduced digital integrated RS485 control drive motor. The driver is designed with 32-bit DSP digital processing technology, variable current technology, low heating technology and so on. It has low vibration, smooth running and low heating, high reliability and other advantages. The user can control the driving motor through RS485, which can meet the application needs of most occasions. Low, medium and high-speed operation are very smooth, ultra-low noise. The driver has the function of power-on auto-adaptive motor, which can automatically generate the optimal operating parameters for different motors and maximize the performance of the motor.

1.2 特性/Characteristics

- 全新 32 位 DSP 技术

New 32 Bit DSP Technology

- 低振动，低噪声，运行平稳

Low vibration, low noise, smooth operation

- 参数上电自动匹配电机功能

Automatic parameter power-on setting function

- 变电流控制使电机发热大为降低

Variable current control greatly reduces the heat generation of the motor.

- 静止时电流自动减半

Automatic halving of current at rest

- 可驱动 4, 6, 8 线两相步进电机

Can drive 4, 6, 8-wire two-phase stepping motor

- 光电隔离单端信号输入（左限位，回零，右限位）

Photoelectric isolation of single-ended signal input (left limit, back zero, right limit)

- 标准 Model DUS RS485 总线协议

Standard Model DUS RS485 bus protocol

- 电流设定方便，可在 0.1-2.2A 之间任意选择

The current setting is convenient and can be selected between 0.1-2.2 A

- 地址拨码设定范围为 1-16

Address dials set to 1-16

- 具有过压、欠压、过流等保护功能

It has the protection functions of overvoltage, undervoltage and overcurrent.

1.3 应用领域/Application areas

适合各种中小型自动化设备和仪器，例如：雕刻机、打标机、切割机、医疗设备、激光照排、绘图仪、数控机床、自动装配设备等。在用户期望低噪声、低振动，低发热和高速度的设备中应用效果特佳。

Suitable for a variety of small and medium-sized automatic equipment and instruments, such as: Engraving Machine, marking machine, cutting machine, medical equipment, laser phototypesetting, plotter, CNC machine tools, automatic assembly equipment. Ideal for applications where the user expects low noise, low vibration, low heat and high speed.

2 性能指标/Performance Index

2.1 电气特性/Electrical characteristics

说明 Explanation	IRO42			
	最小值 Minimum Value	典型值 Typical Value	最大值 Maximal Value	单位 Unit
连续输出电流 Continuous output current	0.1	-	2.2	A
电源电压（直流） Power Supply Voltage (DC)	12	24	32	Vdc
控制信号输入电流 Control signal input current	6	10	16	mA
控制信号输入电压 Control signal input Voltage	-	5	-	Vdc
过压电压点 Overvoltage point	35	36	37	Vdc
通讯频率 Step frequency	1	-	1000	KHz
绝缘电阻 Insulation Resistance	100			MΩ

2.2 适配标准电机/Suitable for standard motor

该一体化驱动器能适配各大电机厂商不同规格的 42 开环混合式步进电机和直线丝杆步进电机，驱动器可以单独对外销售。如果需要采购我司驱动器和电机整套产品，我司一般推荐如下两种标准规格型号，其它规格型号的步进电机或适配丝杆步进电机可以根据客户需求定制。

The integrated driver can be used for 42 open-loop hybrid stepper motors and linear screw stepper motors of different specifications of major motor manufacturers, the driver can be sold separately. If you need to purchase our driver and motor complete set of products, we generally recommend the following two standard models, other models of stepper motor or suitable screw stepper motor can be customized according to customer needs.

型号 (Model No.)	保持转矩 Holding Torque	电机机身长度 Length	驱动器厚度 Drive thickness	重量 Weight
----------------	------------------------	------------------	--------------------------	--------------

	N. m	mm	mm	kg
IR042-04	0.4	48±1	19±1	0.5
IR042-08	0.8	60±1	19±1	0.6

注：该驱动器可定做匹配任意规格的 42 开环步进电机和 42 开环直线丝杆电机

Note: The driver can be customized to match any specifications of 42 open-loop stepper motor and 42 open-loop linear screw motor

2.3 使用环境/Use environment

冷却方式 Cooling Mode		自然冷却或强制风冷 Natural Cooling or forced air cooling
使用环境 Service Environment	场合 Occasion	不能放在其它发热的设备旁，要避免粉尘、油雾、腐蚀性气体，湿度太大及强振动场所，禁止有可燃气体和导电灰尘。 Can not be placed next to other heating equipment, to avoid dust, oil mist, corrosive gases, humidity is too large and strong vibration sites, prohibited combustible gases and conductive dust.
	温度 Temperature	-10°C ~ +50°C
	湿度 Humidity	40 ~ 90%RH
	振动 Vibration	5.9m/s ² MAX
保存温度 Storage temperature		-20°C~60°C
使用海拔 Use Elevation		1000 米以下 Below 1000 meters
重量 Weight		0.7KG

3 安装/Installation

3.1 安装尺寸/Mounting dimensions

IR042 驱动器规格尺寸

IR042 drive dimensions

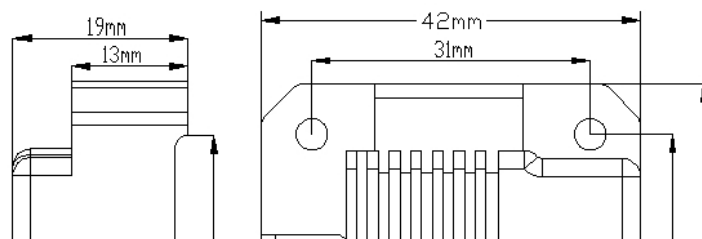

IR042-04 驱动电机规格尺寸及电机矩频特性曲线

IR042-04 drive motor specifications and motor torque-frequency characteristic curve

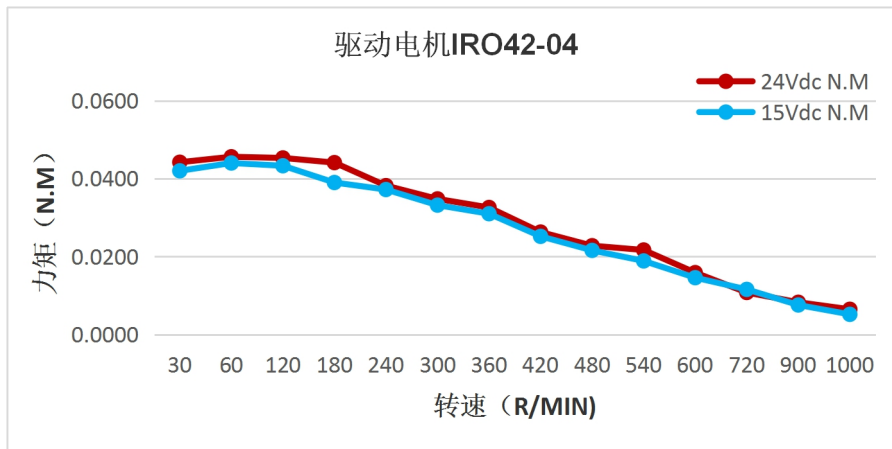
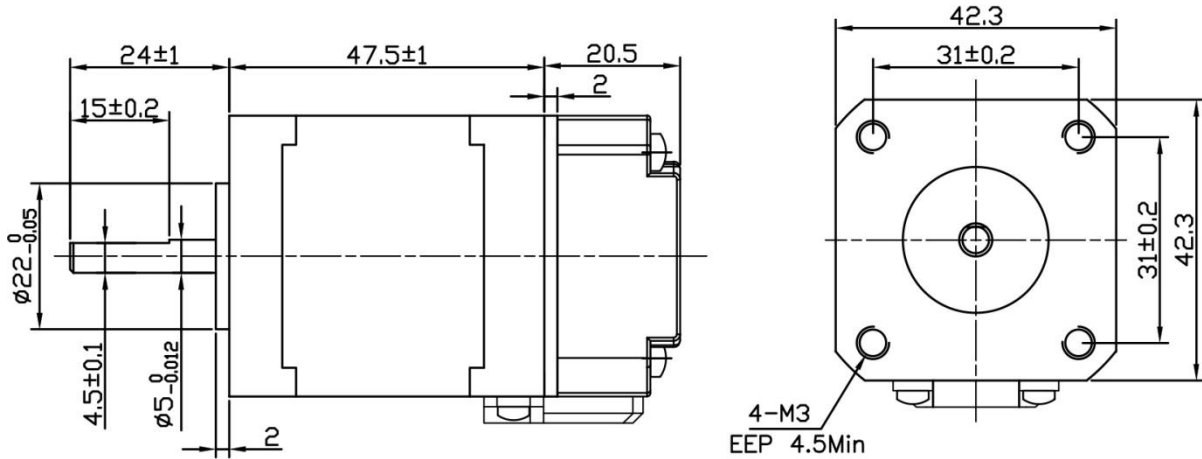

IR042-08 驱动电机规格尺寸及电机矩频特性曲线

IR042-08 drive motor specifications and motor torque-frequency characteristic curve

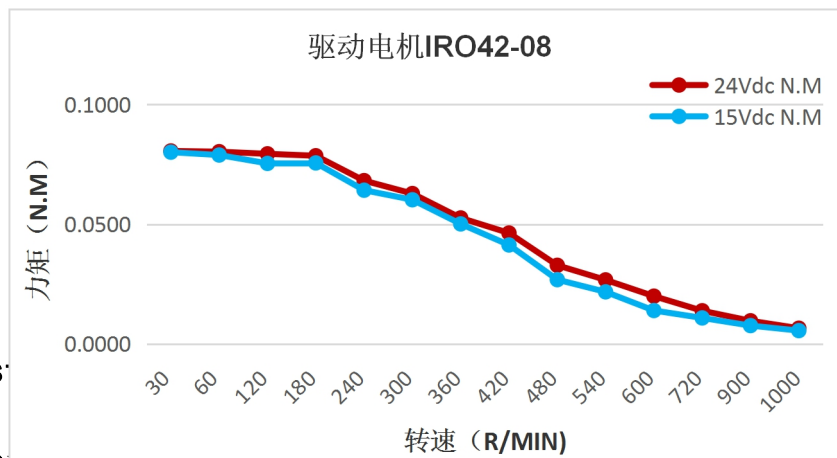
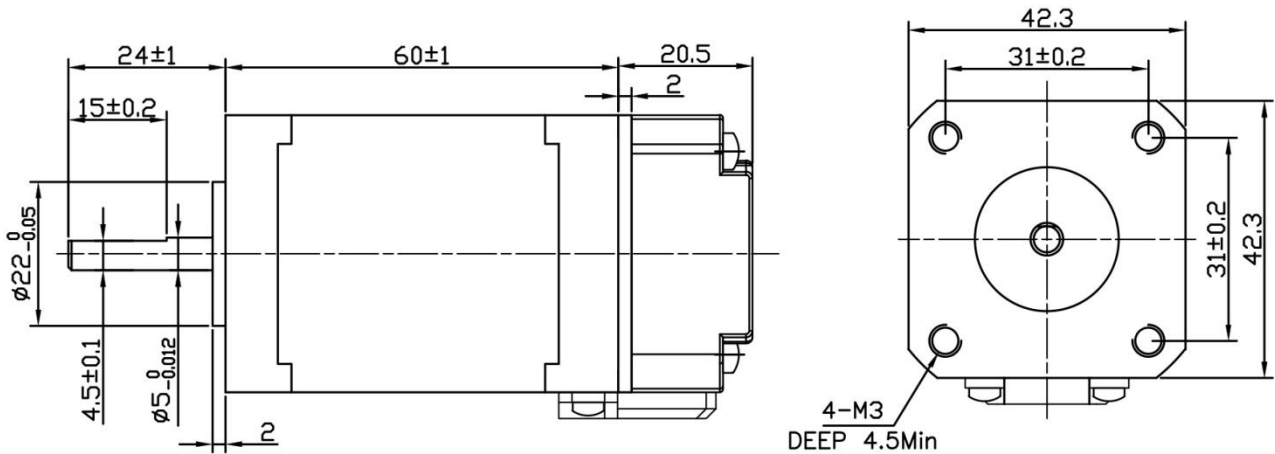

3.2 安装方法/Ins

驱动器的可靠工作温度通常在 60℃ 以内，电机工作温度为 80℃ 以内。

The reliable operating temperature of the driver is usually within 60℃, and the motor operating temperature is within 80℃.

建议使用时选择自动半流方式，马达停止时电流自动减一半，以减少电机和驱动器的发热。

It is recommended to use the automatic semi-flow mode when using the motor. When the motor stops, the current is automatically reduced by half to reduce the heat of the motor and the drive.

安装驱动器时请采用竖着侧面安装，使散热齿形成较强的空气对流。

Install the drive with vertical side mounting so that the heat dissipating teeth form a strong air convection.

必要时机内靠近驱动器处安装风扇，强制散热，保证驱动器在可靠工作温度范围内工作。

Install a fan near the drive when necessary to force heat dissipation to ensure that the drive works within a reliable operating temperature range.

4 驱动器端口与接线/Driver ports and wiring

4.1 接线示意图/Schematic diagram of wiring



4.2 端口定义/Port Definition

4.2.1 LED 灯状态指示/Lamp status indication

绿色 LED 为电源指示灯，当驱动器接通电源时，该 LED 常亮；当驱动器切断电源时或驱动器发生故障时，该 LED 熄灭。

Green LED is the power indicator, when the driver is connected to the power, the LED is always bright; when the driver cut off the power or when the driver failure, the LED extinguished.

4.2.2 控制信号输入端口/Control Signal Input Port

控制信号接口/Control Signal interface

控制信号和电源输入端口采用 8Pin 的 2.0mm 端子。

The control signal and the power supply input port uses the 8Pin 2.0 mm terminal.

引脚号 Pin Number	信号名称 Signal name	功能说明 Function description
1	Vdc	电源正输入：直流电压 15-32Vdc Power positive input: DC VOLTAGE 15-32VDC
2	GND	电源负输入：直流电压的 GND NEGATIVE POWER INPUT: GND OF DC voltage
3	OPT0	脉冲，方向和使能共阳极输入，直流 5Vdc Pulse, direction and enable co-anode input, DC 5VDC
4	PUL-	脉冲控制信号输入（负端）（左限位） Pulse Control Signal Input (negative)(left limit)
5	DIR-	方向控制信号输入（负端）（回零） Direction control signal input (negative)(back to zero)
6	ENA-	使能控制信号输入（负端）（右限位） Enable Control of signal input (negative)(right limit)

7	TXD	RS485 的 TXD Serial port RS485 TXD
8	RXD	RS485 的 RXD Serial port RS485 RXD

注：脉冲，方向和使能接口信号电平只能接受 5V TTL 电平，如果需要 24V，需要在信号输入端口前串联 2KΩ/1W 的限流电阻，或在订货时通知我司定制为只能接受 24V TTL 信号电平的产品。

Note: The pulse, Direction and enable interface signal level can only accept 5 v TTL level, if 24V is needed, the current limiting resistor of 2k/1w should be connected in series before the signal input port, or inform us at the time of ordering to order products which can only accept 24V TTL signal level.

控制信号接口电路

A control signal interface circuit

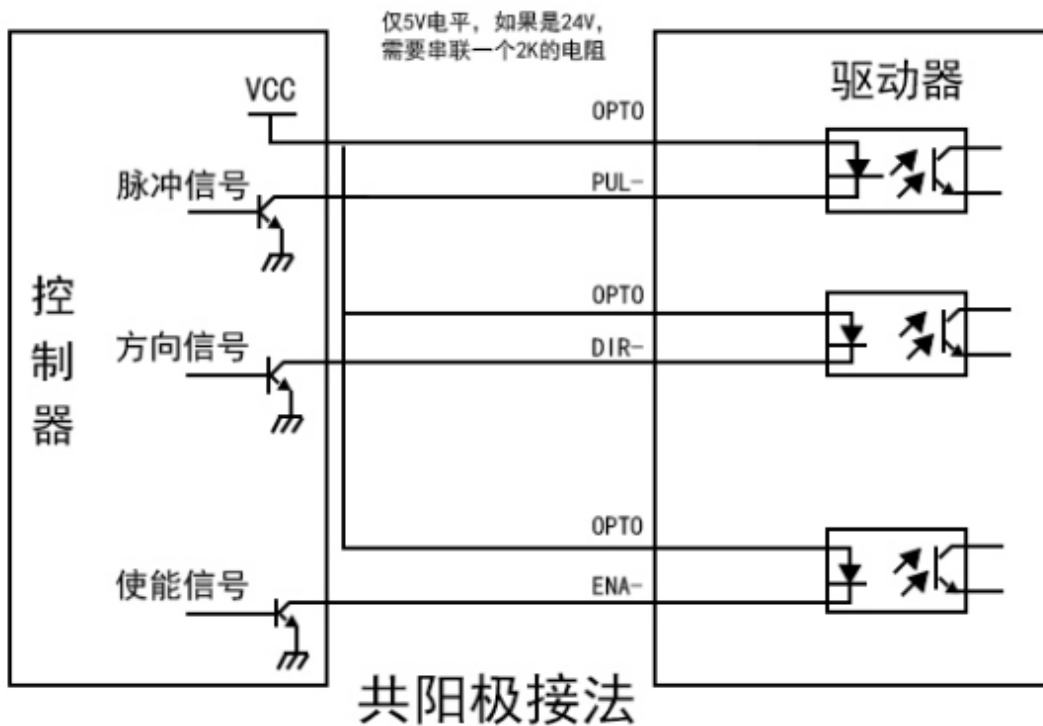

4.2.3 电源及电机输出端口/Output ports of power supply and motor

电机接口/Motor interface

电机接线端口采用 4Pin 的 3.5mm 端子

4 Pin 3.5 mm terminal is used as motor connection port

引脚号 Pin Number	信号名称 Signal name	功能说明 Function description
1	A+	两相步进电机 A+相 Two-phase stepping motor A-phase
2	A-	两相步进电机 A-相 Two-phase stepper motor a-phase
3	B+	两相步进电机 B+相 Two-phase stepping motor B phase

4	B-	两相步进电机 B-相 Two-phase stepping motor b-phase
---	----	--

电源电压在规定范围之间都可以正常工作，驱动器最好采用非稳压型直流电源供电，也可以采用变压器降压+桥式整流+电容滤波。但注意应使整流后电压纹波峰值不超过其规定的最大电压。建议用户使用低于最大电压的直流电压供电，避免电网波动超过驱动器电压工作范围。

The power supply voltage can work normally between the specified ranges. The driver is preferably powered by an unregulated DC power supply, or a transformer buck + bridge rectifier + capacitor filter. Note, however, that the peak voltage ripple after rectification should not exceed its specified maximum voltage. It is recommended that the user supply power with a DC voltage lower than the maximum voltage to prevent the grid from fluctuating beyond the operating range of the driver voltage.

如果使用稳压型开关电源供电，应注意开关电源的输出电流范围需设成最大。

If using a regulated switching power supply, be aware that the output current range of the switching power supply must be set to maximum.

请注意：

Please note:

接线时要注意电源正负极切勿反接；

When wiring, pay attention to the positive and negative poles of the power supply, do not reverse connection;

最好用非稳压型电源；

It is better to use an unstable power supply;

采用非稳压电源时，电源电流输出能力应大于驱动器设定电流的 60%即可；

The output capacity of the power supply current should be greater than 60% of the set current of the driver when an unstable power supply is used;

采用稳压开关电源时，电源的输出电流应大于或等于驱动器的工作电流；

When a regulated switching power supply is adopted, the output current of the power supply shall be greater than or equal to the working current of the driver;

为降低成本，两三个驱动器可共用一个电源，但应保证电源功率足够大。

To reduce costs, two or three drives can share a power supply, but the power supply should be large enough.

5 拨码定义/Dial definition

IR042 驱动器采用 6 位拨码开关设定地址和波特率。详细描述如下：

The IR042 drive uses a 6-bit dial switch to set the address and Baud rate. The details are as follows:

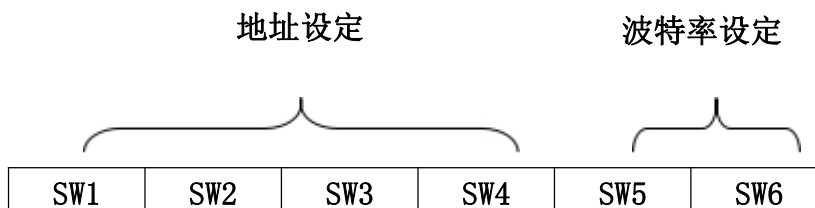

RS485 ID Table

ID	SW1	SW2	SW3	SW4
Reserved (广播地址)	on	on	on	on

1	off	on	on	on
2	on	off	on	on
3	off	off	on	on
4	on	on	off	on
5	off	on	off	on
6	on	off	off	on
7	off	off	off	on
8	on	on	on	off
9	off	on	on	off
10	on	off	on	off
11	off	off	on	off
12	on	on	off	off
13	off	on	off	off
14	on	off	off	off
15	off	off	off	off

注：RS485 的 ID 表格计算值计算公式为： $ID=1*S1+2*S2+4*S3+8*S4$ ，默认 ID 值为 0，0 表示广播地址，可以通过上位机设置其它地址。

Note: The formula for calculating the value of the RS485 ID table is: $ID = 1 * S 1 + 2 * s 2 + 4 * s 3 + 8 * S 4$. The Default ID value is 0,0 for the broadcast address, and other addresses can be set through the host computer.

RS485 Baud Rate Table

Baud Rate	SW5	SW6
9600	on	on
19200	off	on
38400	on	off
57600	off	off

波特率可以根据客户需求定制，如果定制，出厂 SW5 和 SW6 状态均为 ON 时，为客户定制波特率

Baud rate can be customized according to customer needs, if custom, factory SW5 and SW6 status are ON, Custom Baud rate for customers

6 通讯和通讯协议说明/Description of communications and communication protocols

6.1 网络布局/Network layout

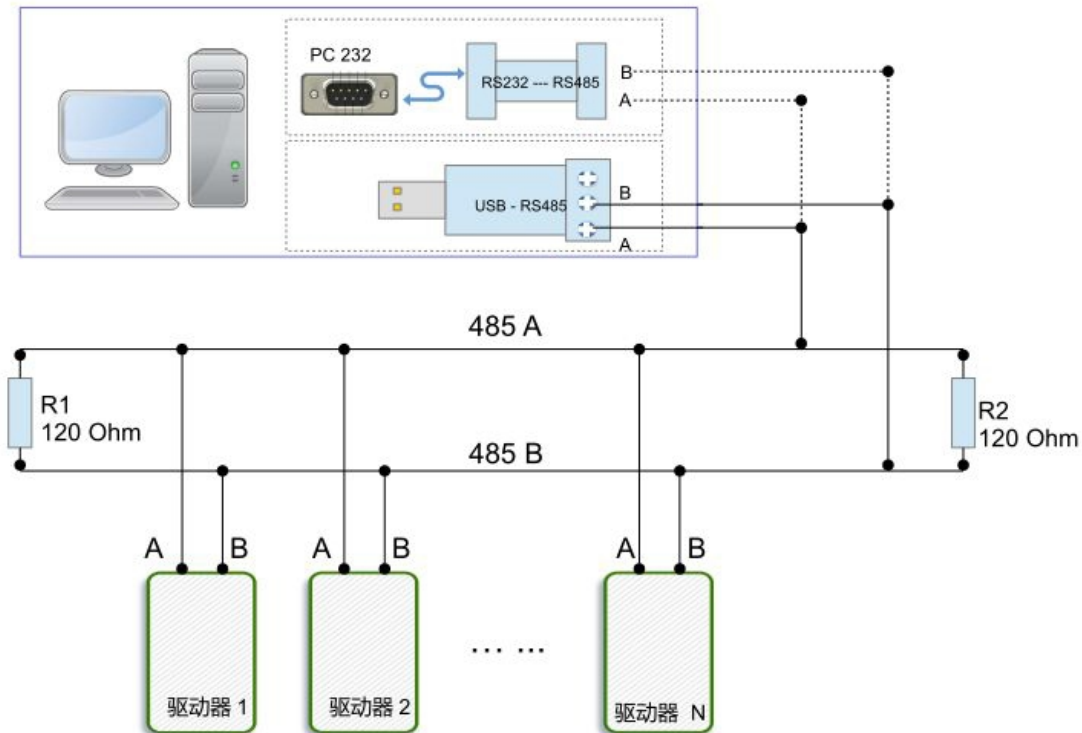

内置梯形加减速曲线生成器，可以梯形加减速，通过通讯命令实现定长运行，连续运行，减速停止，立即停止。内部运行支持绝对位置模式和相对位置模式控制，内置常用回零功能，简化开发。内部脉冲发生器采用 32 位速度、加速度、行程，可以实现宽范围的轨迹发生。

6.2 通讯协议/Communication Protocol

通讯采用标准 MODBUS 协议，支持 0x03(读寄存器)，0x06(写单个寄存器)，0x10(16)(写多个寄存

器)。串口通讯格式：波特率 9600~115200，8 个数据位，无奇偶校验，1 个停止位。

6.2.1 MODBUS 寄存器地址定义/Definition of MODBUS register address

地址	参数名称	属性	默认值	值的范围	寄存器说明
0	峰值电流	R/W/S	5000	1~6000	单位:Ma
1	细分数	R/W/S	6000	200~51200	电机运行一圈所需要的脉冲个数。
2	待机时间	R/W/S	300	100~10000	驱动器进入待机的时间，单位：ms
3	待机电流百分比	R/W/S	50	0~100	单位：%
4	拨码状态	R			
10	滤波时间	R/W/S	4000	50~25600	设定滤波器的滤波时间：us
15	电流环 Kp	R/W/S	1000	10~32767	在自整定为使能时，该项只读；不使能时用户可改写。
16	电流环 Ki	R/W/S	200	0~32767	在自整定为使能时，该项只读；不使能时用户可改写。
18	波特率选择	R/W/S	96	96~1152	96 表示 9600
22	电流有效值	R/W/S	3500	1~4200	单位:Ma
31	设备 ID 号	R			
39	脉冲总数 L	R			接收的外部脉冲个数低 16bit
40	脉冲总数 H	R/W			接收的外部脉冲个数高 16bit 写：写入 1 清除计数器
48	母线电压	R			返回母线电压 单位 0.1V
51	电机运行方向	R/W/S	1	0/1	0：电机运行方向不变 1：电机运行方向取反
60	回零速度	R/W/S	200	0~65535	单位 pulse/s
62	减加速度低 16bit	R/W/S	3200	0~65535	单位 pulse/s ²
63	减加速度高 16bit	R/W/S	0	0~65535	单位 pulse/s ²
64	速度低 16bit	R/W/S	1600	0~65535	单位 pulse/s
65	速度高 16bit	R/W/S	0	0~65535	单位 pulse/s
66	加速度低 16bit	R/W/S	3200	0~65535	单位 pulse/s ²
67	加速度高 16bit	R/W/S	0	0~65535	单位 pulse/s ²
68	行程低 16bit	R/W/S	1600	0~65535	单位 pulse
69	行程高 16bit	R/W/S	0	0~65535	单位 pulse
70	运动指令	R/W	0	0~5	触发相应的运动，然后该地址变为 6 0—减速停止 1—正向定长运动 2—反向定长运动 3—正向连续运动

					4—反向连续运动 5—立即停止 6—默认值，无意义
71	回零命令	R/W	0	0~2	0—退出回零 1—以正向限位信号为零点回零 2—以负向限位信号为零点回零
72	定长运动工作模式	R/W	0	0/1	0: 增量模式 1: 绝对模式
73	设备控制寄存器	R/W/S			具体的位定义见 2.2.1
74	回零限位滤波时间	R/W/S	10	0~65535	1 表示 50us
75	设备状态寄存器	R			具体的位定义见 2.2.2
90	保存参数	R/W	0	0/1	读取该地址： 返回 0: 保存未完成 返回 1: 保存已经完成
91	恢复出厂默认参数	R/W	0	0/1	写入 1 启动清除； 读取该地址： 返回 0: 清除未完成 返回 1: 清除已经完成
92~150	预留	R			预留
位定义		名称说明		默认数值	描述
7~15		预留		0	无
6		IO 触发运动使能 (一般默认 IN1 是触发端口)		0	0——触发端口无作用 1——触发端口可以触发运动
2~5		预留		0	无
1		负限位信号电平 (一般默认 IN3 是负限位)		1	0—光耦关断时发生负限位 1—光耦导通时发生负限位
0		正限位信号电平 (一般默认 IN2 是正限位)		1	0—光耦关断时发生正限位 1—光耦导通时发生正限位

6.2.2 驱动器状态寄存器/Drive Status Register

位定义	名称说明	默认数值	说明
8~15	保留	0	保留
7	运动完成	1	1——内部脉冲发送完成 0——内部脉冲未完成
6	保留	0	0
5	负限位	0	0——无负限位信号 1——有负限位信号
4	正限位	0	0——无正限位信号 1——有正限位信号

2~3	保留	0	
1	过压	0	0——无过压 1——发生过压
0	过流	0	0——无过流 1——发生过流

6.3 回零功能/Return to zero function

6.3.1 以正向限位信号为零点回零/Return to zero with forward limit signal as zero

对寄存器地址71（回零命令）写入“1”后回零过程如下：

第一步：以62~67 寄存器地址设置的速度与加速度正向运行至正限位。

第二步：检测到正限位信号后，减速停止。

第三步：以寄存器地址60（回零速度）设置的速度负方向运行至限位信号。

过程如下图：

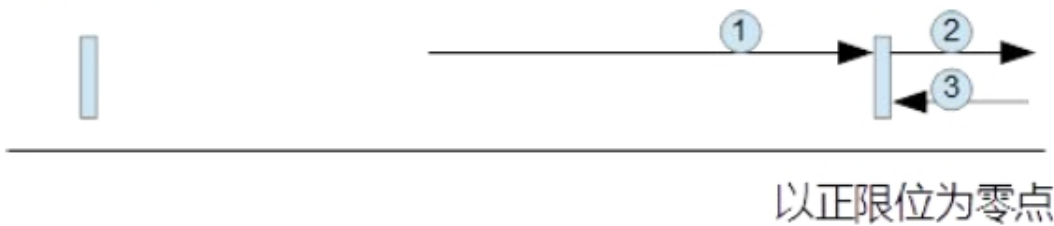

6.3.2 以负向限位信号为零点回零/Return to zero with negative limiting signal as zero

对寄存器地址71（回零命令）写入“2”后回零过程如下：

第一步：以62~67 寄存器地址设置的速度与加速度负向运行至负限位。

第二步：检测到负限位信号后，减速停止。

第三步：以寄存器地址60（回零速度）设置的速度正方向运行至限位信号。

过程如下图：



6.3.3 退出回零/Exit back to zero

对寄存器地址71（回零命令）写入“0”后驱动器退出回零过程，减速停止。

在完成回零后，客户根据需要（如在绝对位置模式下），在寄存器地址40写入1

可以清除脉冲计数器。

6.4 MODBUS 常用功能码/MODBUS common function code

6.4.1 读保持寄存器命令 0x03/Read Hold Register Command 0x03

主机->从机数据

设备地址	功能码	寄存器地址		读寄存器个数		CRC校验	
01	03	00	00	00	01	85	0A

从机->主机数据

设备地址	功能码	返回字节数	寄存器数数	CRC校验		
01	03	02	0A	8C	BF	41

从机返回电流值（寄存器地址00）为2700mA。

6.4.2 写单个寄存器命令 0x06/Write Single Register Command 0x06

主机->从机数据

设备地址	功能码	寄存器地址		写入数据		CRC校验	
01	06	00	40	06	40	8A	4E

从机->主机数据

设备地址	功能码	寄存器地址		写入数据		CRC校验	
01	06	00	40	06	40	8A	4E

对从机的速度低16bit（寄存器地址64）写入1600pulse/s。

6.4.3 写多个寄存器命令 0x10/Write Multiple Register Commands 0x10

主机->从机数据

设备地址	功能码	起始地址		写入数量		字节数	写入内容		写入内容		CRC校验	
01	10	00	44	00	02	04	38	80	00	01	3B	24

从机->主机数据

设备地址	功能码	起始地址		写入数量		CRC校验	
01	10	00	44	00	02	01	DD

对从机的行程低16bit（寄存器地址64）写入14464，行程高16bit（寄存器地址65）写入1，即行程总数为80000pulse。

6.5 CRC 校验例程/CRC check routine

以下例程通过C 语言计算CRC

```

Uint16 Funct_CRC16(unsigned char * puchMsg, Uint16 DataLen)
{
    Uint16 i,j,tmp;
    Uint16 crcdata=0xFFFF;
    for(i=0;i<DataLen;i++)
    {
        crcdata=(*puchMsg)^crcdata;
        puchMsg++;
        for(j=0;j<8;j++)
        {
            tmp=crcdata&0x0001;
            crcdata=crcdata>>1;
            if(tmp){
                crcdata=crcdata^0xA001;
            }
        }
    }
    return crcdata;
}
    
```

7 保修及售后服务 /Warranty and after-sales service

请保留好包装箱以便运输、储存或需要退回本公司维修时使用。一年保修期：

Please keep the packing box for transportation, storage or need to return to the company for maintenance. One year warranty period:

来自本驱动器使用一年内因为产品自身的原因造成的损坏，负责保修。

From the use of this drive within one year because of the product itself caused by the damage, responsible for the warranty.

不在保修之列：/Not covered by warranty:

不恰当的接线、电源电压和用户外围配置造成的损坏。/Damage caused by improper wiring, power supply voltage and user peripheral configuration.

无本公司书面授权条件下，用户擅自对产品进行更改。/Without the written authorization of the company, users make changes to the products without authorization.

超出电气和环境的要求使用。/Use beyond electrical and environmental requirements.

驱动器序列编号被撕下或无法辨认。/The drive serial number has been torn off or is unreadable.

外壳被明显破坏。/The outer shell was visibly damaged.

不可抗拒的灾害。/An irresistible disaster. 6.2 售后服务 /Aftersales Service

添加微信或者拨打电话



(+86) 18926788846

Email: Tech@TQKTEC.COM

您拨打电话之前，请先记录以下信息：

Before you call, please record the following information:

故障现象/Fault phenomenon

产品型号和序列号/Product model and serial number

安装日期或者生产日期/Installation date or production date